

Harte Aufsatzbacken

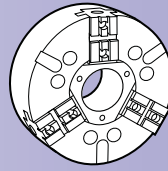

Kreuzversatz

SMW-AUTOBLOK Berg Forkardt Kitagawa Röhms Schunk

GUA Harte Aufsatzbacken

GUA

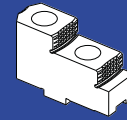

Seite 84

GSK Harte Stangen-Greifbacken

GSK



Seite 85

GGK Harte Greifbacken

GGK

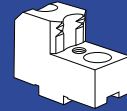

Seite 86

ALB Auflagebolzen

ALB

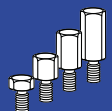

Seite 86

Harte, umkehrbare Aufsatzbacken

GUA für Backenschnellwechsel

Kreuzversatz

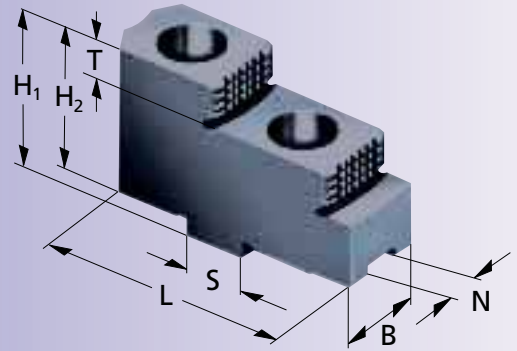

Typ	Id.-Nr.	B	H ₁	H ₂	L	T	N	S	kg/Satz	SMW-AUTOBLOK	SMW	Berg	Forkardt	Kitagawa	Röhms	Schunk
GUA 160	012484	20	36,5	32,5	63	7,5	8	18	0,6	HG-N 160 HG-F 160 KNCS-N 170	RMG 160 HG 160 KNSP 160 KNCS 160 KNCS 175	KHNC 160 KHNC 185	F 160 KTNC 160 KTNCV 175 FNC 175 F+160		Duro 160 Duro-NC 160 Duro-NC 175 Duro-NCE 160	ROTA-S 160 THW 165 ROTA-G 160 ROTA-NC-W 185 ROTA-S PLUS 160
GUA 200	012485	22	42	38	72	10	10	20	0,8	HG-N 210 HG-F 210 KNCS-N 210 KNCS-N 225 KNCS-NB 210	RMG 200 HG 200 KNSP 200 KNCS 200 KNCS 210	KHNC 200	F 200 KTNC 200 KTNCV 200 FNC 200 F+200	QJ 8" (QJ 210-43)	Duro 200 Duro-NC 200 Duro-NC 225 Duro-NCE 200	ROTA-S 200 THW 210-F/R THWB 210 ROTA-G 200 ROTA-NC-W 225 ROTA-S PLUS 200 ROTA-NC-WF 210
GUA 250	012486	30	55	50	90	14	12	20	1,9	HG-N 260 HG-N 315 HG-F 260 KNCS-N 260 KNCS-N 315 KNCS-NB 260 KNCS-NB 315	RMG 250 HG 250 HG 315 KNCS 250 KNCS 260 KNCS 315	KHNC 250 KHNC 315	F 250 UNC 250/315 KTNC 250 KTNCV 250 KTNC 265 KTNC 280 KTNC 315 KTNCV 315 FNC 250 FNC 315 F+250	QJ 10" (QJ 254-65) QJ 12" (QJ 315-78)	Duro 250 Duro-NC 250 Duro-NCE 250 Duro-NCE 315	ROTA-S 250 ROTA-G 250 THW 250-F/R THW 265-F/R THWB 265 THW 315 R ROTA-NC-WF 250 ROTA-S PLUS 250 ROTA-NC-W 265 ROTA-G 315 ROTA-NC-W 315 ROTA-NC-WF 315
GUA 400	012487	36	62	56	105	15	12	26	3,2	HG-N 400 HG-F 315 KNCS-N 400 KNCS-NB 400	RMG 315 HG 400 KNCS 400	KHNC 400	F 315 UNC 400 KTNC 360 KTNC 400 FNC 400 F+315	KTNCV 400	Duro 315 Duro-NC 315 Duro-NCE 400	ROTA-S 315 ROTA-G 315 THWB 315 THW 400-F/R ROTA-S PLUS 315 ROTA-G 400 ROTA-NC-W 400
GUA 500	012488	45	75	70	130	20	18	30	10,8	HG-N 500 HG-N 630 HG-F 400 HG-F 500 KNCS-N 500 KNCS-N 630 KNCS-NB 500 KNCS-NB 630 KNCS-NB 800	RMG 500 HG 630 KNCS 500 KNCS 630	KHNC 500	F 400/500 L UNC 500 KTNC 500/630 KTNCV 500/630 FNC 500/630 F+400		Duro 400 Duro-NC 400 Duro 500 Duro-NC 500 Duro-NCE 500	ROTA-S 400 ROTA-S 500 THWB 400 THW 500-F/R THW 630-R ROTA-S PLUS 400 ROTA-S PLUS 500 ROTA-G 500
GUA 631	035959	65	89	97	185	30	24	40	15	HG-F 630			F 630			ROTA-S 630 ROTA-S PLUS 630 ROTA-G 630



Nur auf dem Futter unter Spanndruck
ausgeschliffene Spannbacken

garantieren hohe Spannwiederholgenauigkeiten.

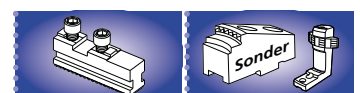

Seite 98
Seite 120

Seite 95
Seite 140

Harte Stangengreifbacken

GSK für Backenschnellwechsel

Kreuzversatz

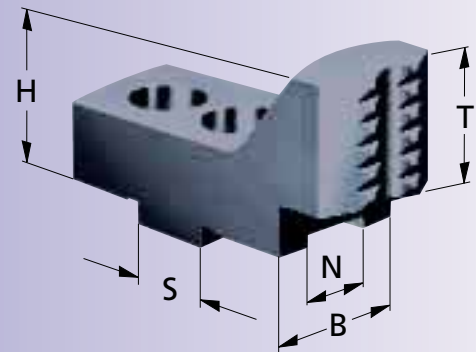

Typ	Id.-Nr.	Spann- bereich Ø	B	H	T	N	S	kg/ Satz	SMW- AUTOBLOK	SMW	Berg	Forkardt	Kitagawa	Röhms	Schunk
GSK 160	091359	12-40	20	40	30	8	18	0,8	HG-N 160 HG-F 160 KNCS-N 170	RMG 160 HG 160 KNSP 160 KNCS 160 KNCS 175	KHNC 160 KHNC 185	F 160 KTNC 160 KTNCV 160 KTNCV 175 FNC 175 F+160		Duro 160 Duro-NC 160 Duro-NC 175 Duro-NCE 160	ROTA-S 160 THW 165 ROTA-G 160 ROTA NC-W 185 ROTA-S PLUS 160
GSK 200	091360	15-50	22	40	30	10	20	0,8	HG-N 210 HG-F 210 KNCS-N 210 KNCS-N 225 KNCS-NB 210	RMG 200 HG 200 KNSP 200 KNCS 200 KNCS 210	KHNC 200	F 200 KTNC 200 KTNCV 200 FNC 200 F+200	QJ 8" (QJ 210-43)	Duro 200 Duro-NC 200 Duro-NC 225 Duro-NCE 200	ROTA-S 200 THW 210-F/R THWB 210 ROTA-G 200 ROTA-NC-W 225 ROTA-S PLUS 200 ROTA-NC-WF 210
GSK 250	091361	15-60	30	45	35	12	20	1,4	HG-N 260 HG-N 315 HG-F 260 KNCS-N 260 KNCS-N 315 KNCS-NB 260 KNCS-NB 315	RMG 250 HG 250 HG 315 KNCS 250 KNCS 260 KNCS 315	KHNC 250 KHNC 315	F 250 UNC 250/315 KTNC 250 KTNCV 250 KTNC 265 KTNC 280 KTNC 315 KTNCV 315 FNC 250 FNC 315 F+250	QJ 10" (QJ 254-65) QJ 12" (QJ 315-78)	Duro 250 Duro-NC 250 Duro-NCE 250 Duro-NCE 315	ROTA-S 250 ROTA-G 250 THW 250-F/R THW 265-F/R THWB 265 THW 315 R ROTA NC-WF 250 ROTA-S PLUS 250 ROTA NC-W 265 ROTA-G 315 ROTA NC-W 315 ROTA-NC-WF 315
GSK 400	091362	30-90	35	50	40	12	26	2,2	HG-N 400 HG-F 315 KNCS-N 400 KNCS-NB 400	RMG 315 HG 400 KNCS 400	KHNC 400	F 315 UNC 400 KTNC 360 KTNC 400 FNC 400 F+315	KTNCV 400	Duro 315 Duro-NC 315 Duro-NCE 400	ROTA-S 315 THW 315 F THWB 315 THW 400-F/R ROTA-S PLUS 315 ROTA-G 400 ROTA NC-W 400

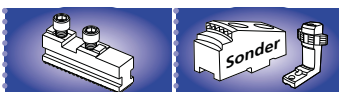

Seite 98
Seite 120

Seite 95
Seite 140

Harte Greifspanbacken

GGK für Backenschnellwechsel

Kreuzversatz

für SMW-AUTOBLOK-Futter

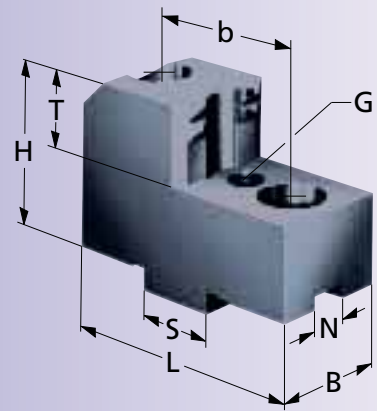

Typ	Id.-Nr.	B	H	T	G	N	S	b	L	kg/ Satz	SMW- AUTOBLOK	Spannbereich Ø		Spannbereich Ø	
												Außen-A ₁	Innen-J ₁	Außen-A ₂	Innen-J ₂
GGK 1751	012464	25	40	16	M5	8	18	32	64	0,9	KNCS-N 140	25-48	129-158	-	-
GGK 1753	012466								60	1,0		47-76	102-130	-	-
GGK 1754	012467								56	0,9		73-101	77-105	-	-
GGK 1751	012464	25	40	16	M5	8	18	32	64	0,9	KNCS-N 170	25-60	132-170	40-78	150-188
GGK 1753	012466								60	1,0		HG-N 160	50-88	105-142	68-106
GGK 1754	012467								56	0,9	HG-F 160	75-113	79-117	93-131	97-135
GGK 1755	012468								70	1,0		-	45-61	-	45-79
GGK 2001	012469	28	45	20	M5	10	20	40	87	1,9	KNCS-N 210	29-56	186-240	37-94	224-280
GGK 2002	012470								66	1,3		KNCS-NB 210	60-117	125-182	89-155
GGK 2003	012471								66	1,3	HG-N 210	97-153	88-145	135-191	126-183
GGK 2004	012472								85	1,7	HG-F 210	-	54-86	-	68-124
GGK 2001	012469	28	45	20	M5	10	20	40	87	1,9	KNCS-N 225	29-70	190-257	38-105	225-292
GGK 2002	012470								66	1,3		KNCS-NB 225	65-131	129-196	99-165
GGK 2003	012471								66	1,3	HG-N 225	101-167	93-159	136-202	128-194
GGK 2004	012472								85	1,7	HG-F 225	-	54-100	-	69-135
GGK 2501	012473	40	50	22	M6	12	20	40	94	3,0	KNCS-N 260	35-66	192-258	64-130	256-322
GGK 2502	012474								72	2,3		KNCS-NB 260	70-136	122-188	134-200
GGK 2503	012475								78	2,6	HG-N 260	100-166	92-158	164-230	156-222
GGK 2504	012476								108	3,2	HG-F 260	-	-	-	70-134
GGK 2501	012473	40	50	22	M6	12	20	40	94	3,0	KNCS-N 315	35-109	202-301	98-198	290-390
GGK 2502	012474								72	2,3		KNCS-NB 315	80-179	132-231	168-268
GGK 2503	012475								78	2,6	HG-N 315	110-209	102-201	198-298	190-290
GGK 2505	012477								84	2,8	HG-F 315	-	80-165	-	-
GGK 4001	012478	50	55	25	M8	12	26	54	104	4,8	KNCS-N 400	60-182	252-375	139-260	331-453
GGK 4002	012479								91	3,5		KNCS-NB 400	176-299	136-259	256-377
GGK 4003	012480								92	3,6	HG-N 400	-	119-242	-	-
GGK 5001	012481	60	74	35	M8	18	30	60	125	8,8	KNCS-N 500	65-212	256-426	166-334	378-546
GGK 5002	012482								108	6,7		KNCS-NB 500	164-332	136-304	286-454
GGK 5003	012483	50	74	35	M8	18	30	60	130	6,2	HG-N/HG-F 500	-	90-238	-	-
GGK 5001	012481	60	74	35	M8	18	30	60	125	8,8	KNCS-N 630	65-225	255-437	243-637	455-637
GGK 5002	012482								108	6,7		KNCS-NB 630	163-345	135-317	363-545
											HG-N 630	-	90-251	-	-

Spannbereiche

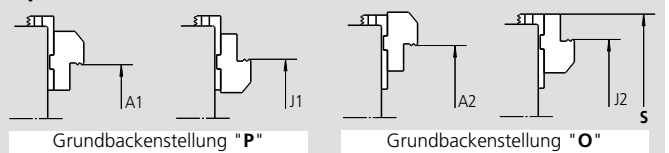

Auflagebolzen

ALB

Typ	Id.-Nr.	G	H	SW
ALB 505	016510	M5	5	10
ALB 510	016508		10	
ALB 515	016509		15	
ALB 605	016513	M6	5	10
ALB 610	016511		10	
ALB 615	016512		15	
ALB 620	017602	M8	20	13
ALB 805	017603		5	
ALB 810	016514		10	
ALB 815	016515		15	
ALB 820	016516		20	
ALB 825	081191		25	

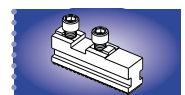
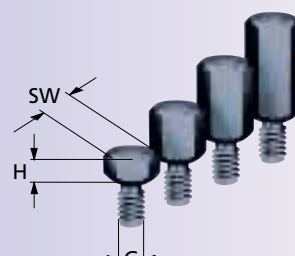

Seite 98
Seite 120



Seite 95
Seite 140

Harte Greifspanbacken

GGK für Backenschnellwechsel

Kreuzversatz

für SMW-AUTOBLOK-Futter

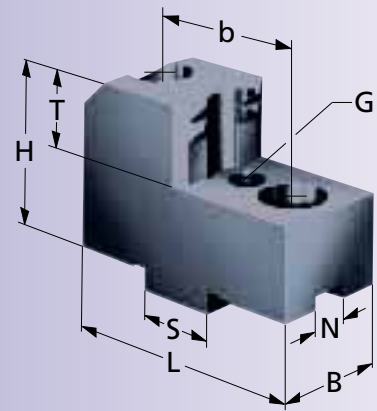

Typ	Id.-Nr.	B	H	T	G	N	S	b	L	kg/ Satz	SMW	Spannbereich Ø Außen-A ₁	Spannbereich Ø Innen-J ₁	Spannbereich Ø Außen-A ₂	Spannbereich Ø Innen-J ₂
GGK 1751	012464	25	40	16	M5	8	18	32	64	0,9	KNCS 175	25-58	138-168	38-72	48-82
GGK 1752	012465								68	1,0					
GGK 1753	012466								60	1,0					
GGK 1754	012467								56	0,9					
GGK 1755	012468								70	1,0					
GGK 2001	012469	28	45	20	M5	10	20	40	87	1,9	KNCS 200 KNCS 210	60-100	125-165	95-135	160-200
GGK 2002	012470								66	1,3					
GGK 2003	012471								66	1,3					
GGK 2004	012472								85	1,7					
GGK 2501	012473	40	50	22	M6	12	20	40	94	3,0	KNCS 250	40-64	190-250	64-128	252-310
GGK 2502	012474								72	2,3					
GGK 2503	012475								78	2,6					
GGK 2504	012476								108	3,2					
GGK 2501	012473	40	50	22	M6	12	20	40	94	3,0	KNCS 260	40-75	193-266	65-135	255-330
GGK 2502	012474								72	2,3					
GGK 2503	012475								78	2,6					
GGK 2504	012476								108	3,2					
GGK 2501	012473	40	50	22	M6	12	20	40	94	3,0	KNCS 315	49-95	202-288	95-180	288-370
GGK 2503	012475								78	2,6					
GGK 2505	012477								84	2,8					
GGK 2501	012473	40	50	22	M6	12	20	40	94	3,0	KNCS 315-91	45-110	210-200	110-200	300-370
GGK 2503	012475								78	2,6					
GGK 2505	012477								84	2,8					
GGK 4001	012478	50	55	25	M8	12	26	54	104	4,8	KNCS 400	50-160	230-350	115-235	305-425
GGK 4002	012479								91	3,5					
GGK 4003	012480								92	3,6					
GGK 5001	012481	60	74	35	M8	18	30	60	125	8,8	KNCS 500	80-190	260-400	170-310	375-520
GGK 5002	012482								108	6,7					
GGK 5003	012483	50	74	35	M8	18	30	60	130	6,2					
GGK 5001	012481	60	74	35	M8	18	30	60	125	8,8	KNCS 630	80-240	265-450	240-440	460-650
GGK 5002	012482								108	6,7					

Spannbereiche

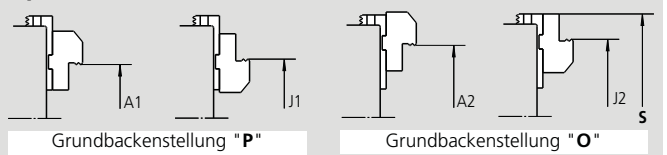

Harte Aufsatzbacken
(Kreuzversatz)

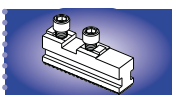

Seite 98

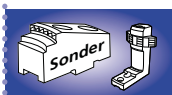

Seite 95

Seite 140

Auflagebolzen

ALB

Typ	Id.-Nr.	G	H	SW
ALB 505	016510	M5	5	10
ALB 510	016508		10	
ALB 515	016509		15	
ALB 605	016513	M6	5	10
ALB 610	016511		10	
ALB 615	016512		15	
ALB 620	017602	M8	20	13
ALB 805	017603		5	
ALB 810	016514		10	
ALB 815	016515	15		
ALB 820	016516	20		
ALB 825	081191	25		

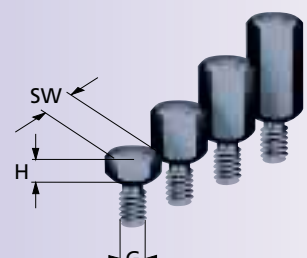

Harte Greifspannbacken

GGK für Backenschnellwechsel

Kreuzversatz

für Berg-Futter

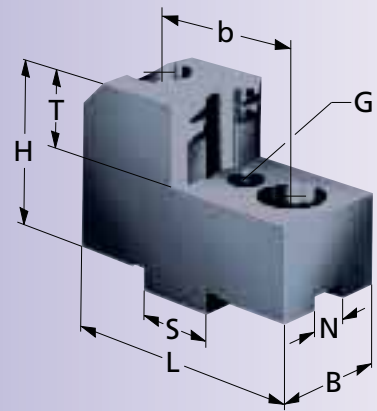

Typ	Id.-Nr.	B	H	T	G	N	S	b	L	kg/ Satz	Berg	Spannbereich Ø		Spannbereich Ø		
												Außen-A ₁	Innen-J ₁	Außen-A ₂	Innen-J ₂	
GGK 1751	012464	25	40	16	M5	8	18	32	64	0,9	KHNC 160	28-65	140-175	55-90	110-145	110-145
GGK 1752	012465								68	1,0						
GGK 1753	012466								60	1,0						
GGK 1754	012467								56	0,9						
GGK 1755	012468								70	1,0						
GGK 2001	012469	28	45	20	M5	10	20	40	87	1,9	KHNC 200	30-45	120-175	50-95	108-158	175-220
GGK 2002	012470								66	1,3						
GGK 2003	012471								66	1,3						
GGK 2004	012472								85	1,7						
GGK 2501	012473	40	50	22	M6	12	20	40	94	3,0	KHNC 250	38-80	195-270	75-145	145-195	270-320
GGK 2502	012474								72	2,3						
GGK 2503	012475								78	2,6						
GGK 2504	012476								108	3,2						
GGK 2501	012473	40	50	22	M6	12	20	40	94	3,0	KHNC 315	40-150	210-330	90-120	190-310	280-370
GGK 2502	012474								78	2,6						
GGK 2505	012477								84	2,8						
GGK 4001	012478	50	55	25	M8	12	26	54	104	4,8	KHNC 400	50-205	230-385	115-270	230-385	305-450
GGK 4002	012479								91	3,5						
GGK 4003	012480								92	3,6						
GGK 5001	012481	60	74	35	M8	18	30	60	125	8,8	KHNC 500	70-280	280-480	180-380	300-500	385-590
GGK 5002	012482								108	6,7						
GGK 5003	012483	50	74	35	M8	18	30	60	130	6,2						

Spannbereiche

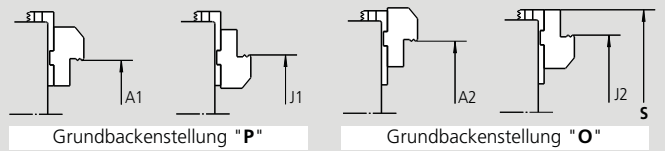

Auflagebolzen

ALB

Typ	Id.-Nr.	G	H	SW
ALB 505	016510	M5	5	10
ALB 510	016508		10	
ALB 515	016509		15	
ALB 605	016513	M6	5	10
ALB 610	016511		10	
ALB 615	016512		15	
ALB 620	017602	M8	20	13
ALB 805	017603		5	
ALB 810	016514		10	
ALB 815	016515		15	
ALB 820	016516		20	
ALB 825	081191		25	

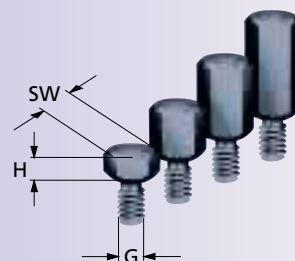

Seite 95
Seite 140

Harte Greifspannbacken

GGK für Backenschnellwechsel

Kreuzversatz

für Forkardt-Futter

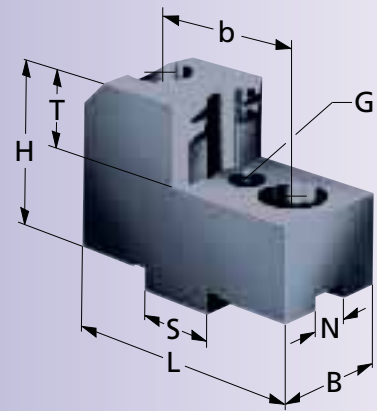

Typ	Id.-Nr.	B	H	T	G	N	S	b	L	kg/ Satz	Forkardt	Spannbereich Ø Außen-A ₁	Spannbereich Ø Innen-J ₁	Spannbereich Ø Außen-A ₂	Spannbereich Ø Innen-J ₂
GGK 1751	012464	25	40	16	M5	8	18	32	64	0,9	3 KTNC 160 F 160 F+160	25-38	135-150	45-72	102-128
GGK 1752	012465								68	1,0					
GGK 1753	012466								60	1,0					
GGK 1754	012467								56	0,9					
GGK 1755	012468								70	1,0					
GGK 2001	012469	28	45	20	M5	10	20	40	87	1,9	3 KTNC 200 F 200 F+200	52-78	120-140	95-125	160-190
GGK 2002	012470								66	1,3					
GGK 2003	012471								66	1,3					
GGK 2004	012472								85	1,7					
GGK 2501	012473	40	50	22	M6	12	20	40	94	3,0	3 KTNC 250 F 250 F+250	180-216	120-150	140-172	262-290
GGK 2502	012474								72	2,3					
GGK 2503	012475								78	2,6					
GGK 2504	012476								108	3,2					
GGK 2501	012473	40	50	22	M6	12	20	40	94	3,0	3 KTNC 280	38-52	190-242	74-128	262-310
GGK 2502	012474								78	2,6					
GGK 2505	012477								84	2,8					
GGK 4001	012478	50	55	25	M8	12	26	54	104	4,8	3 KTNC 360 F 315 F+315	50-110	220-300	105-190	295-380
GGK 4002	012479								91	3,5					
GGK 4003	012480								92	3,6					
GGK 5001	012481	60	74	35	M8	18	30	60	125	8,8	3 KTNC 500 F 500 L F+500 L	70-190	245-400	150-310	370-520
GGK 5002	012482								108	6,7					
GGK 5003	012483	50	74	35	M8	18	30	60	130	6,2					
GGK 5001	012481	60	74	35	M8	18	30	60	125	8,8	3 KTNC 630	70-300	225-510	150-420	360-630
GGK 5002	012482								108	6,7					
GGK 5003	012483								130	6,2					

Spannbereiche

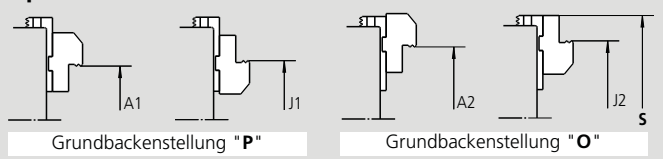

Harte Aufsatzbacken
Kreuzversatz

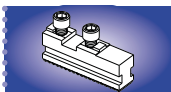

Seite 120

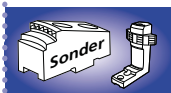

Seite 95
Seite 140

Auflagebolzen

ALB

Typ	Id.-Nr.	G	H	SW
ALB 505	016510	M5	5	10
ALB 510	016508		10	
ALB 515	016509		15	
ALB 605	016513	M6	5	10
ALB 610	016511		10	
ALB 615	016512		15	
ALB 620	017602	M8	20	13
ALB 805	017603		5	
ALB 810	016514		10	
ALB 815	016515		15	
ALB 820	016516		20	
ALB 825	081191		25	

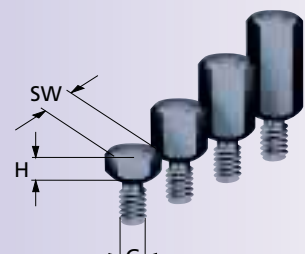

Harte Greifspannbacken

GGK für Backenschnellwechsel

Kreuzversatz

für Forkardt-Futter

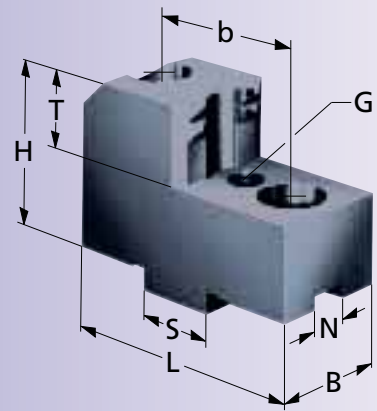

Typ	Id.-Nr.	B	H	T	G	N	S	b	L	kg/ Satz	Forkardt	Spannbereich Ø		Spannbereich Ø	
												Außen-A ₁	Innen-J ₁	Außen-A ₂	Innen-J ₂
GGK 1751	012464	25	40	16	M5	8	18	32	64	0,9	KTNCV 175 FNC 175	30-80	126-190	48-110	160-220
GGK 1752	012465								68	1,0					
GGK 1753	012466								60	1,0					
GGK 1754	012467								56	0,9					
GGK 1755	012468								70	1,0					
GGK 2001	012469	28	45	20	M5	10	20	40	87	1,9	KTNCV 200 FNC 200	44-106	120-180	100-162	172-234
GGK 2002	012470								66	1,3					
GGK 2003	012471								66	1,3					
GGK 2004	012472								85	1,7					
GGK 2501	012473	40	50	22	M6	12	20	40	94	3,0	KTNCV 250 FNC 250	40-90	200-285	80-170	272-360
GGK 2502	012474								72	2,3					
GGK 2503	012475								78	2,6					
GGK 2504	012476								108	3,2					
GGK 2501	012473	40	50	22	M6	12	20	40	94	3,0	KTNCV 315 FNC 315	40-118	200-320	80-200	275-395
GGK 2502	012474								78	2,6					
GGK 2505	012477								84	2,8					
GGK 4001	012478	50	55	25	M8	12	26	54	104	4,8	KTNCV 400 FNC 400	50-180	220-340	100-265	315-425
GGK 4002	012479								91	3,5					
GGK 4003	012480								92	3,6					
GGK 5001	012481	60	74	35	M8	18	30	60	125	8,8	KTNCV 500 FNC 500	60-235	255-440	160-350	375-560
GGK 5002	012482								108	6,7					
GGK 5003	012483	50	74	35	M8	18	30	60	130	6,2					
GGK 5001	012481	60	74	35	M8	18	30	60	125	8,8	KTNCV 630 FNC 630	60-335	225-525	160-460	375-675
GGK 5002	012482								108	6,7					
GGK 5003	012483								130	6,2					

Spannbereiche

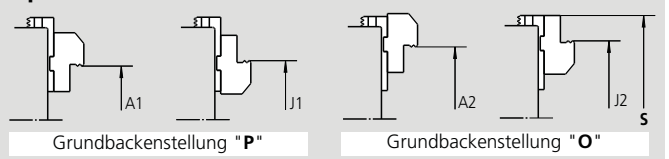

Auflagebolzen

ALB

Typ	Id.-Nr.	G	H	SW
ALB 505	016510	M5	5	10
ALB 510	016508		10	
ALB 515	016509		15	
ALB 605	016513	M6	5	10
ALB 610	016511		10	
ALB 615	016512		15	
ALB 620	017602	M8	20	13
ALB 805	017603		5	
ALB 810	016514		10	
ALB 815	016515		15	
ALB 820	016516		20	
ALB 825	081191		25	

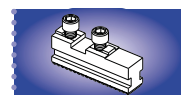
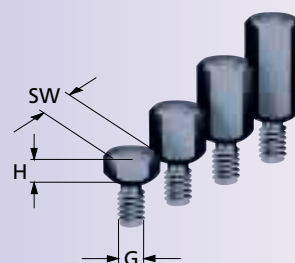

Seite 120



Seite 95
Seite 140

Harte Greifspannbacken

GGK für Backenschnellwechsel

Kreuzversatz

für Kitagawa-Futter

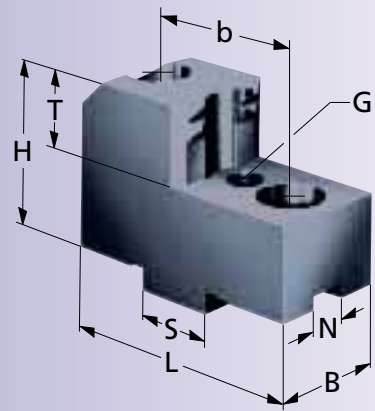

Typ	Id.-Nr.	B	H	T	G	N	S	b	L	kg/ Satz	Kitagawa	Spannbereich Ø Außen-A ₁	Spannbereich Ø Innen-J ₁	Spannbereich Ø Außen-A ₂	Spannbereich Ø Innen-J ₂
GGK 2001	012469	28	45	20	M5	10	20	40	87	1,9	QJ 8" (QJ 210-43)	30-62	134-183	61-110	182-230
GGK 2002	012470								66	1,3		68-117			
GGK 2003	012471								66	1,3		105-154		153-280	
GGK 2004	012472								85	1,7			60-89		
GGK 2501	012473	40	50	22	M6	12	20	40	94	3,0	QJ 10" (QJ 254-65)	40-78	197-270	82-154	142-215
GGK 2502	012474								72	2,3		76-148			
GGK 2503	012475								78	2,6		98-170		174-246	
GGK 2504	012476								108	3,2			67-135		
GGK 2501	012473	40	50	22	M6	12	20	40	94	3,0	QJ 12" (QJ 315-78)	40-96	138-236	101-174	238-316
GGK 2502	012474								72	2,3		82-166			
GGK 2503	012475								78	2,6		104-188		192-266	
GGK 2505	012477								84	2,8			80-175		

Spannbereiche

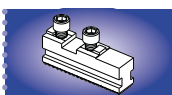
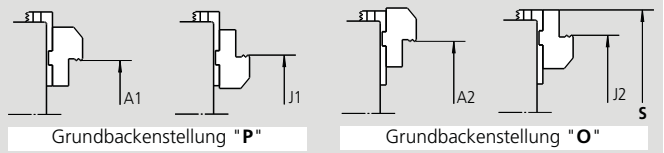

Seite 120

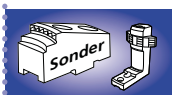

Seite 95
Seite 140

Auflagebolzen

ALB

Typ	Id.-Nr.	G	H	SW
ALB 505	016510	M5	5	10
ALB 510	016508		10	
ALB 515	016509		15	
ALB 605	016513	M6	5	10
ALB 610	016511		10	
ALB 615	016512		15	
ALB 620	017602		20	
ALB 805	017603	M8	5	13
ALB 810	016514		10	
ALB 815	016515		15	
ALB 820	016516		20	
ALB 825	081191		25	

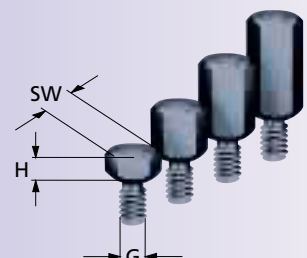

Harte Greifspannbacken

GGK für Backenschnellwechsel

Kreuzversatz

für Röhm-Futter

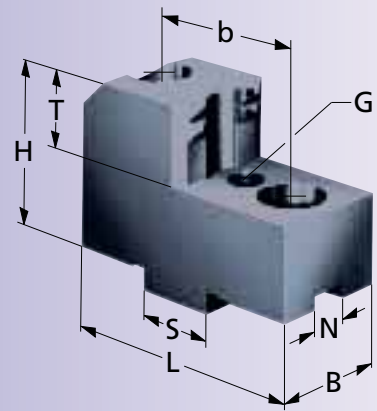

Typ	Id.-Nr.	B	H	T	G	N	S	b	L	kg/ Satz	Röhm	Spannbereich Ø		Spannbereich Ø	
												Außen-A ₁	Innen-J ₁	Außen-A ₂	Innen-J ₂
GGK 1751	012464	25	40	16	M5	8	18	32	64	0,9	Duro-NC 160	28-70	-	50-100	-
GGK 1752	012465								68	1,0	Duro-NCE 160		138-180	85-135	
GGK 1753	012466								60	1,0	Duro 160		110-150	85-135	
GGK 1754	012467								56	0,9			85-120	110-160	
GGK 1755	012468								70	1,0					60-100
GGK 1751	012464	25	40	16	M5	8	18	32	64	0,9	Duro-NC 175	36-78	-	58-108	-
GGK 1752	012465								68	1,0			146-188	93-143	
GGK 1753	012466								60	1,0			118-158	118-168	
GGK 1754	012467								56	0,9			93-128		
GGK 1755	012468								70	1,0					68-108
GGK 2001	012469	28	45	20	M5	10	20	40	87	1,9	Duro-NC 200	55-130	125-195	100-180	170-240
GGK 2002	012470								66	1,3	Duro-NCE 200		90-160	140-210	
GGK 2003	012471								66	1,3	Duro 200		55-100		
GGK 2004	012472								85	1,7					
GGK 2501	012473	40	50	22	M6	12	20	40	94	3,0	Duro-NC 250	38-95	195-280	80-160	270-300
GGK 2502	012474								72	2,3	Duro-NCE 250		125-205	145-225	
GGK 2503	012475								78	2,6	Duro 250		110-180	180-260	
GGK 2504	012476								108	3,2					80-170
GGK 2501	012473	40	50	22	M6	12	20	40	94	3,0	Duro-NCE 315	66-139	223-324	108-204	298-344
GGK 2502	012474								72	2,3			153-249	173-269	
GGK 2503	012475								78	2,6			138-224	208-304	
GGK 2504	012476								108	3,2					108-214
GGK 4001	012478	50	55	25	M8	12	26	54	104	4,8	Duro-NC 315	50-150	220-330	120-220	
GGK 4002	012479								91	3,5	Duro 315		110-220	220-320	
GGK 4003	012480								92	3,6			85-200		
GGK 4001	012478	50	55	25	M8	12	26	54	104	4,8	Duro-NCE 400	128-206	298-386	198-276	
GGK 4002	012479								91	3,5			188-276	298-376	
GGK 4003	012480								92	3,6			163-256		
GGK 5001	012481	60	74	35	M8	18	30	60	125	8,8	Duro-NC 400	65-175	260-380	165-285	380-430
GGK 5002	012482								108	6,7	Duro 400		140-260	285-400	
GGK 5003	012483	50	74	35	M8	18	30	60	130	6,2			105-200		
GGK 5001	012481	60	74	35	M8	18	30	60	125	8,8	Duro-NCE 500	101-289	296-494	221-404	436-604
GGK 5002	012482								108	6,7			176-374	346-534	
GGK 5003	012483	50	74	35	M8	18	30	60	130	6,2					
GGK 5001	012481	60	74	35	M8	18	30	60	125	8,8	Duro-NC 500	65-235	260-440	185-350	400-550
GGK 5002	012482								108	6,7	Duro 500		140-320	310-480	

Spannbereiche

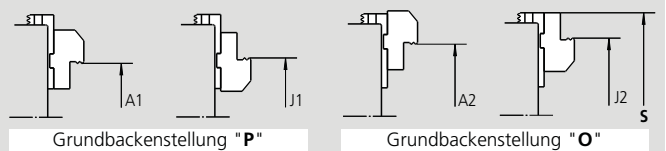

Auflagebolzen

ALB

Typ	Id.-Nr.	G	H	SW
ALB 505	016510	M5	5	10
ALB 510	016508		10	
ALB 515	016509		15	
ALB 605	016513	M6	5	10
ALB 610	016511		10	
ALB 615	016512		15	
ALB 620	017602		20	
ALB 805	017603	M8	5	13
ALB 810	016514		10	
ALB 815	016515		15	
ALB 820	016516		20	
ALB 825	081191		25	

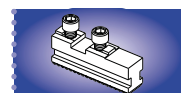
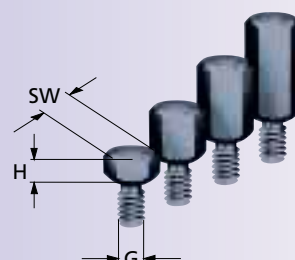

Seite 120



Seite 95
Seite 140

Harte Greifspanbacken

GGK für Backenschnellwechsel

Kreuzversatz

für Schunk-Futter

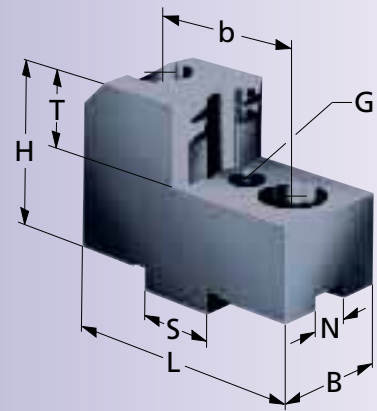

Typ	Id.-Nr.	B	H	T	G	N	S	b	L	kg/ Satz	Schunk	Spannbereich Ø		Spannbereich Ø	
												Außen-A ₁	Innen-J ₁	Außen-A ₂	Innen-J ₂
GGK 1751	012464	25	40	16	M5	8	18	32	64	0,9	ROTA-S 160	25-50	-	-	-
GGK 1752	012465								68	1,0	THW 165		133-160		
GGK 1753	012466								60	1,0	ROTA-G 160		105-134	66-95	
GGK 1754	012467								56	0,9	ROTA NC-W 185		78-106	95-125	
GGK 1755	012468								70	1,0	ROTA-S PLUS 160				47-80
GGK 2001	012469	28	45	20	M5	10	20	40	87	1,9	ROTA-S 200	30-55	185-230	45-94	-
GGK 2002	012470								66	1,3	THW 210-F-R	60-110	130-178	100-145	165-215
GGK 2003	012471								66	1,3	ROTA-G 200	100-150	90-135	140-185	130-175
GGK 2004	012472								85	1,7	ROTA-NC-W 225	-	55-84	-	70-120
											ROTA-S PLUS 200				
											ROTA-NC-WF 210				
											THWB 210				
GGK 2501	012473	40	50	22	M6	12	20	40	94	3,0	ROTA-S 250	35-70	200-265	65-138	265-330
GGK 2502	012474								72	2,3	ROTA-G 250	80-145	130-195	143-205	190-260
GGK 2503	012475								78	2,6	THW 250-F-R	110-175	100-165	174-237	165-230
GGK 2504	012476								108	3,2	THW 265-F-R	-	-	-	80-145
											ROTA NC-WF 250				
											ROTA-S PLUS 250				
											ROTA NC-W 265				
											THWB 250				
GGK 2501	012473	40	50	22	M6	12	20	40	94	3,0	ROTA-G 315	40-92	205-280	94-179	294-370
GGK 2502	012474								72	3,0	ROTA NC-W 315	85-161	135-210	170-249	219-300
GGK 2503	012475								78	2,6	ROTA NC-WF 315	115-190	105-180	203-278	194-270
GGK 2505	012477								84	2,8	THW 315-R	-	85-150	-	-
GGK 4001	012478	50	55	25	M8	12	26	54	104	4,8	ROTA-S 315	50-162	230-350	118-240	305-430
GGK 4002	012479								91	3,5	THW 315-F	162-283	110-230	240-360	190-308
GGK 4003	012480								92	3,6	THW 400-F-R	-	100-220	-	-
											ROTA-S PLUS 315				
											ROTA-G 400				
											ROTA NC-W 400				
											THWB 315				
GGK 5001	012481	60	74	35	M8	18	30	60	125	8,8	ROTA-S 400	80-190	260-400	170-310	380-520
GGK 5002	012482								108	6,7	ROTA-S 500	170-310	140-280	265-405	260-400
GGK 5003	012483	50	74	35	M8	18	30	60	130	6,2	THW 500-F-R	-	100-210	-	-
											THW 630-R				
											ROTA-S PLUS 400/500				
											ROTA-G 500				
											THWB 400				
GGK 5001	012481	60	74	35	M8	18	30	60	125	8,8	ROTA-S 630	80-230	260-445	220-430	430-640
GGK 5002	012482								108	6,7	ROTA-G 630	170-350	140-325	315-525	310-520
GGK 5003	012483	50	74	35	M8	18	30	60	130	6,2	THW 630-R		100-250		
											ROTA-S PLUS 630				

Harte Aufsatzbacken
Kreuzversatz

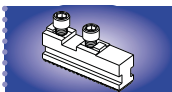

Seite 98
Seite 120

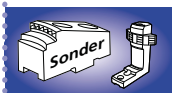

Seite 95
Seite 140

Auflagebolzen

ALB

Typ	Id.-Nr.	G	H	SW
ALB 505	016510	M5	5	10
ALB 510	016508		10	
ALB 515	016509		15	
ALB 605	016513	M6	5	10
ALB 610	016511		10	
ALB 615	016512		15	
ALB 620	017602		20	
ALB 805	017603	M8	5	13
ALB 810	016514		10	
ALB 815	016515		15	
ALB 820	016516		20	
ALB 825	081191		25	

