

Harte Aufsatzbacken

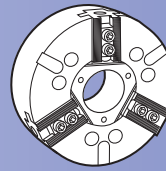

Spitzverzahnung metrisch
1,5 x 60° bzw. 3 x 60°

SMW-AUTOBLOK Howa Kitagawa Schunk

MHB-M Harte Aufsatzbacken umkehrbar

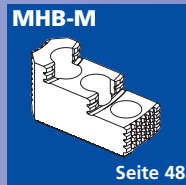

SGA-M Harte Greifbacken Außenspannung
ALB Auflagebolzen

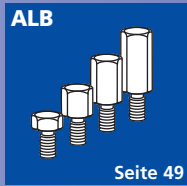
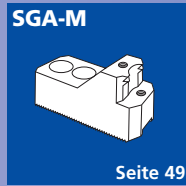

SGI-M Harte Greifbacken Innenspannung
ALB Auflagebolzen

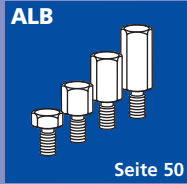
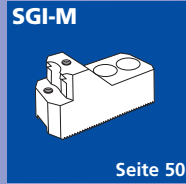

GSG-M Harte Stangen-Greifbacken

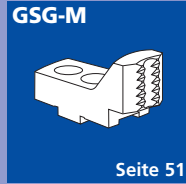

Harte Aufsatzbacken
Spitzverzahnung metrisch

Harte, umkehrbare Aufsatzbacken

MHB-M

Spitzverzahnung metrisch
1,5 x 60° bzw. 3 x 60°

Spitzverzahnung geschliffen

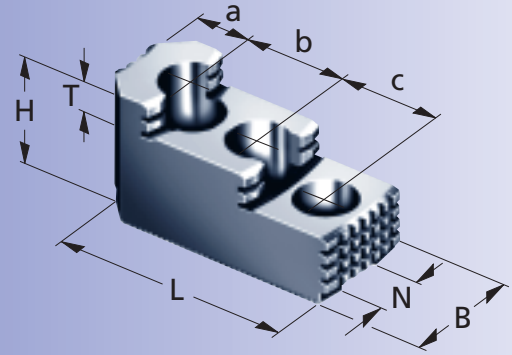

Typ	Id.-Nr.	B	H	L	T	N	Spitz- verzahnung	a + b + c f. DIN 912	kg/ Satz	SMW- AUTOBLOK	Howa	Kitagawa	Schunk
MHB-M 120	081032	35	44	80	10	12	1,5 x 60°	24+20+20 M10	1,6	AN-M 165 AL-M 165 BH-M 165 BHM-FC 165	HO1MA6 HO7MA6 HO15M6 HO22M6 HO27M6 HO24M6 HO37M6 HO47M6	B-06 • B-160 B-206 • N-06 N-160 HJA 5-6 • AS 165 HO-6 • HOH 160 HOS 6 B106 HOH 206 B 07	HSL 165 (1,5 x 60°) ROTA-NCK 165
MHB-M 121	12081627	34	39	67	10	12	1,5 x 60°	14+20+20 M10	0,93	BB-M 175 PB-M 165 PBI-M 165 HB-M 165 HFKN-M 165	HO22M6 HO27M6 HO24M6 HO37M6 HO47M6	HOS 6 B106 HOH 206 B 07	
MHB-M 140	12082127	40	45	86	10,5	14	1,5 x 60°	19+25+25 M12	2,0	AN-M 210 AL-M 210 BH-M 210 BHM-FC 210 BB-M 210 PB-M 210 PBI-M 210 HB-M 210 HFKN-M 210	HO7MA8 HO15M8 HO23M8	B-08 • B-200 B-208 • N-08 N-200 • B 108 HJA 6-8 • AS 210 HO-8 • HOB-8 HOS-8 • HOH-200 HOH 8 HOH-108 HOH 208	HSL 210 (1,5 x 60°) ROTA-NCK 210
MHB-M 160 ¹	081045	40	42	83	15	16	1,5 x 60°	17+25+25 M12	1,5		HO7MA10 HO15M10 HO22M8 HO27M8 HO24M8 HO37M8 HO47M8		
MHB-M 161	12082627	45	56	100	15,5	16	1,5 x 60°	23+30+30 M12	2,9	AN-M 250 AL-M 250 BH-M 250 BHM-FC 250 BB-M 250 PB-M 250 PBI-M 250 HB-M 250 HFKN-M 260		B-10 • B-210 B-250 • N-10 N-250 • AS 250 HJA 6-10/8-10 HO-10 HOB/HOS-10 HOH-250 B110 • HOH 10 HOH 210	HSL 250 (1,5 x 60°) ROTA-NCK 250
MHB-M 180	081038	50	60	109	15	18	1,5 x 60°	24+30+30 M14	5,1		HO7MA12 HO15M12 HO22M10 HO23M12 HO24M10 HO27M10 HO47M10 HO22MA10 HO37M10	B-12 • B-300 N-12 • N 300 HO-12 HOB-12 • HOS-12 HOH-300 HOH-12 HJA 6/8-12 HL 6-12 HLA 6/8-15	HSL 315 (1,5 x 60°) ROTA-NCK 315
MHB-M 211	12083037	45	56	105	13,5	21	1,5 x 60°	26+30+30 M16	2,85	AN-M 315 AL-M 315 BH-M 315 BHM-FC 315 BB-M 315 PB-M 315 PBI-M 315 HB-M 315 HFKN-M 315		B 212	ROTA-NCK 315
MHB-M 400	12084007	55	73	120	22	21	1,5 x 60°	30+34+34 M16	5,1	GH-M 400			
MHB-M 500 ¹	037126	55	73	145	32	25,5	3 x 60°	46+38+38 M20	6,7	HFKN-M 400 HFKN-M 500			

¹ nur 1 Spannstufe

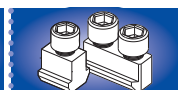

Seite 53
Seite 140

ab Seite 56

Harte Greifspanbacken

SGA-M für Außenspannung

Spitzverzahnung metrisch
1,5 x 60°

Spitzverzahnung geschliffen

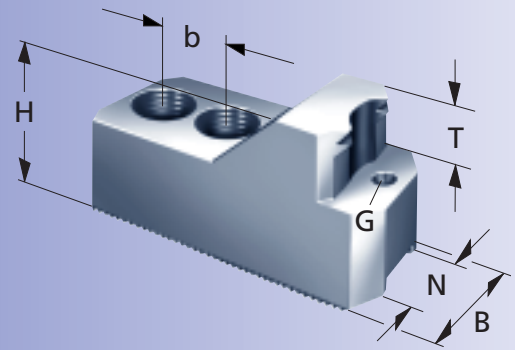

Typ	Id.-Nr.	Spann- bereich Ø	B	H	T	G	N	Spitzver- zahnung	b	kg/ Satz	SMW- AUTOBLOK	Howa	Kitagawa	Schunk
SGA-M 010	081156	30-45	30	40	20	M6	12	1,5 x 60°	20	1,0	AN-M 165 AL-M 165 BH-M 165	HO1MA6 HO7MA6 HO15M6	AS 165 B-06 • B-160 • B-206 HJA 5-6	HSL 165 (1,5 x 60°) ROTA-NCK 165
SGA-M 020	081157	40-65												
SGA-M 030	081158	65-85												
SGA-M 040	081159	85-105												
SGA-M 050	081160	105-125												
SGA-M 060	081161	30-50	35	50	25	M6	14	1,5 x 60°	25	1,4	AN-M 210 AL-M 210 BH-M 210	HO7MA8 HO15M8 HO23M8	AS 210 B-08 • B-200 • B-208 HJA 6-8	HSL 210 (1,5 x 60°) ROTA-NCK 210
SGA-M 070	081162	50-75												
SGA-M 080	081163	75-100												
SGA-M 090	081164	100-130												
SGA-M 100	081165	130-160												
SGA-M 200	081175	40-65	40	50	25	M6	16	1,5 x 60°	30	1,4	AN-M 250 AL-M 250 BH-M 250		AS 250 B-10 • B-210 • B-250 HJA 6-10/8-10 HO-10K	HSL 250 (1,5 x 60°) ROTA-NCK 250
SGA-M 210	081176	65-100												
SGA-M 220	081177	100-150												
SGA-M 230	081178	150-200												
SGA-M 280	081181	50-90	45	60	30	M8	18	1,5 x 60°	30	3,9		HO7MA12 HO15M12 HO23M12	B-12 • B-300 HJA 6/8-12 HLA 6-12 HLA 6/8-15	HSL 315 (1,5 x 60°) ROTA-NCK 315
SGA-M 290	081182	90-140												
SGA-M 300	081183	140-190												
SGA-M 310	081184	190-245												
SGA-M 320	081185	245-300												
SGA-M 331	081186	50-100	50	60	25	M8	21	1,5 x 60°	30	4,2	AN-M 315 AL-M 315 BH-M 315		B 212	ROTA-NCK 315
SGA-M 341	081187	100-160												
SGA-M 351	081188	160-230												
SGA-M 361	081189	230-300												
SGA-M 331	081186	128-186	50	60	25	M8	21	1,5 x 60°	30	4,2	GH-M 400			
SGA-M 341	081187	178-246												
SGA-M 351	081188	238-316												
SGA-M 361	081189	308-386												
SGA-M 371	085743	60-100	60	80	34	M8	22	1,5 x 60°	43	4,2			B 15 • B 18 B-380 • B-450	HSL 400 (1,5 x 60°)
SGA-M 372	085744	100-150												
SGA-M 373	085745	150-200												
SGA-M 374	085746	200-250												
SGA-M 375	085747	250-300								4,3				
SGA-M 376	085748	300-350								4,3				

Harte Aufsatzbacken
Spitzverzahnung metrisch

Auflagebolzen

ALB

Typ	Id.-Nr.	G	H	SW
ALB 605	016513	M6	5	10
ALB 610	016511		10	
ALB 615	016512		15	
ALB 620	017602		20	
ALB 805	017603	M8	5	13
ALB 810	016514		10	
ALB 815	016515		15	
ALB 820	016516		20	
ALB 825	081191		25	

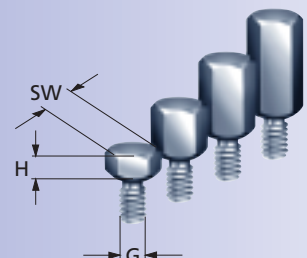

Seite 53
Seite 140

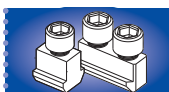

Seite 62

Harte Greifspannbacken

SGI-M für Innenspannung

Spitzverzahnung metrisch
1,5 x 60°

Spitzverzahnung geschliffen

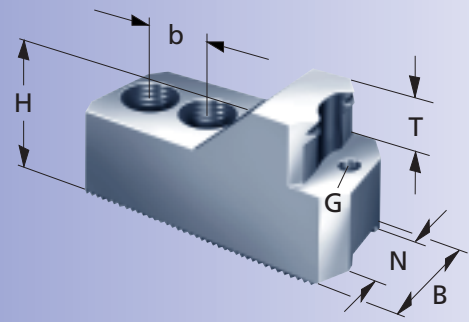

Typ	Id.-Nr.	Spann- bereich Ø	B	H	T	G	N	Spitzver- zahnung	b	kg/ Satz	SMW- AUTOBLOK	Howa	Kitagawa	Schunk
SGI-M 010	081192	45-60	30	40	20	M6	12	1,5 x 60°	20	1,2	AN-M 165	HO1MA6	AS 165	HSL 165
SGI-M 020	081193	60-80									AL-M 165	HO7MA6	B-06•B-160•B-206	(1,5 x 60°)
SGI-M 030	081194	80-100									BH-M 165	HO15M6	HJA 5-6	ROTA-NCK 165
SGI-M 040	081195	100-120									BHM-FC 165	HO22M6	HOH 160	
SGI-M 050	081196	120-140									HFKN-M 165	HO27M6	HOH06K HOH206K N-06•N-160	
SGI-M 060	081197	50-70	35	50	25	M6	14	1,5 x 60°	25	1,7	AN-M 210	HO7MA8	AS 210	HSL 210
SGI-M 070	081198	70-95									AL-M 210	HO15M8	B-08•B-200•B-208	(1,5 x 60°)
SGI-M 080	081199	95-120									BH-M 210	HO23M8	HJA 6-8	ROTA-NCK 210
SGI-M 090	081200	120-145									BHFC 210		HOH-08K	
SGI-M 100	081201	145-170									HFKN-M 210		HOH 200 HOH-208K N-08•N-200	
SGI-M 200	081211	55-80	40	55	25	M8	16	1,5 x 60°	30	2,4	AN-M 250		AS 250	HSL 250
SGI-M 210	081212	80-120									AL-M 250		B-10•B-210•B-250	(1,5 x 60°)
SGI-M 220	081213	120-170									BH-M 250		HJA 6-10/8-10	ROTA-NCK 250
SGI-M 230	081214	170-220									BHFC 250 HFKN-M 260		HO-10K HOB/HOS 10 HOH-250 N-10•N-250	
SGI-M 280	081216	50-90	45	60	30	M8	18	1,5 x 60°	30	3,2		HO7MA12	B-12•B-300	HSL 315
SGI-M 290	081217	90-140									HO15M12	HJA 6/8-12	HJA 6/8-12	(1,5 x 60°)
SGI-M 300	081218	140-190									HO23M12	HLA 6-12	HLA 6/8-15	ROTA-NCK 315
SGI-M 310	081219	190-245										HO-12 HOB/HOS12 HOH12K HOH-300 N-12•N-300		
SGI-M 331	081220	80-140	50	60	25	M8	21	1,5 x 60°	30	4,2	AN-M 315		B 212	
SGI-M 341	081221	140-200									AL-M 315			
SGI-M 351	081222	200-260									BH-M 315			
SGI-M 361	081223	260-310									BHFC 315 HFKN-M 315			
SGI-M 331	081220	158-226	50	60	25	M8	21	1,5 x 60°	30	4,2	GH-M 400			
SGI-M 341	081221	218-286												
SGI-M 351	081222	278-346												
SGI-M 361	081223	338-396												

Auflagebolzen

ALB

Typ	Id.-Nr.	G	H	SW
ALB 605	016513	M6	5	10
ALB 610	016511		10	
ALB 615	016512		15	
ALB 620	017602		20	
ALB 805	017603	M8	5	13
ALB 810	016514		10	
ALB 815	016515		15	
ALB 820	016516		20	
ALB 825	081191		25	

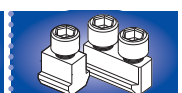
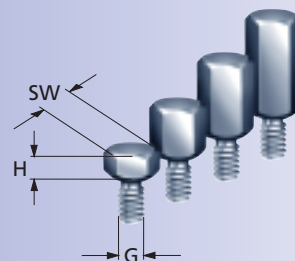

Harte Stangengreifbacken

GSG-M

Spitzverzahnung metrisch
1,5 x 60°

Spitzverzahnung geschliffen

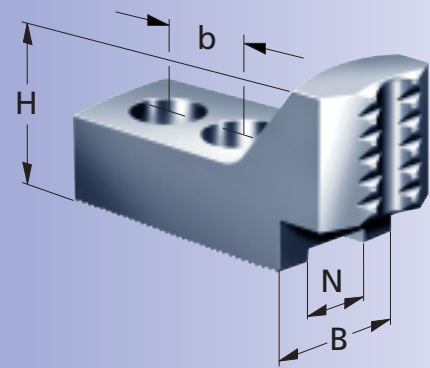

Typ	Id.-Nr.	Spannbereich Ø	B	H	N	Spitzverzahnung	b für DIN 912	kg/Satz	SMW-AUTOBLOK	Howa	Kitagawa	Schunk
GSG-M 120	091347	15-30	30	40	12	1,5 x 60°	20 M10	1,1	AN-M 165 AL-M 165 BH-M 165 BHM-FC 165 BB-M 175 PB-M 165 PBI-M 165 HB-M 165 HFKN-M 165	HO1MA6 HO7MA6 HO15M6 HO22M6 HO27M6 HO24M6 HO37M6 HO47M6	B-06 • B-160 B-206 • N-06 N-160 HJA 5-6 • AS 165 HO-6 • HOH 160 HOS 6 • B106 HOH 206 B 07	HSL 165 (1,5 x 60°) ROTA-NCK 165
GSG-M 140	091348	20-50	35	45	14	1,5 x 60°	25 M12	1,6	AN-M 210 AL-M 210 BH-M 210 BHM-FC 210 BB-M 210 PB-M 210 PBI-M 210 HB-M 210 HFKN-M 210	HO7MA8 HO15M8 HO23M8	B-08 • B-200 B-208 • N-08 N-200 • B 108 HJA 6-8 • AS 210 HO-8 • HOB-8 HOS-8 • HOH-200 HOH 8 • HOH-108 HOH 208	HSL 210 (1,5 x 60°) ROTA-NCK 210
GSG-M 160	091349	20-60	40	50	16	1,5 x 60°	30 M12	1,8	AN-M 250 AL-M 250 BH-M 250 BHM-FC 250 BB-M 250 PB-M 250 PBI-M 250 HB-M 250 HFKN-M 260		B-10 • B-210 B-250 • N-10 N-250 • AS 250 HJA 6-10/8-10 HO-10 HOB/HOS-10 HOH-250 B110 • HOH 10 HOH 210	HSL 250 (1,5 x 60°) ROTA-NCK 250
GSG-M 180	091350	30-80	50	50	18	1,5 x 60°	30 M14	3,6		HO7MA12 HO15M12 HO22M10 HO23M12 HO24M10 HO27M10 HO47M10 HO22MA10 HO37M10	B-12 • B-300 N-12 • N 300 HO-12 HOB-12 • HOS-12 HOH-300 HOH-12 HJA 6/8-12 HL 6-12 HLA 6/8-15	HSL 315 (1,5 x 60°) ROTA-NCK 315
GSG-M 210	091351	30-80	50	50	21	1,5 x 60°	30 M16	3,6	AN-M 315 AL-M 315 BH-M 315 BHM-FC 315 BB-M 315 PB-M 315 PBI-M 315 HB-M 315 HFKN-M 315		B-212	

Harte Aufsatzbacken
Spitzverzahnung metrisch



Seite 53
Seite 140

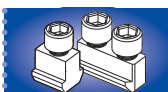

Seite 62