

Harte Aufsatzbacken

Spitzverzahnung Zoll
1/16" x 90° bzw. 3/32" x 90°

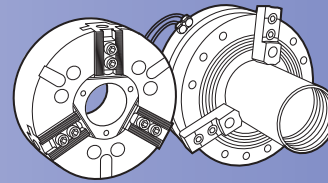
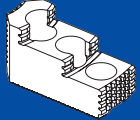
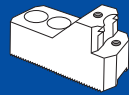
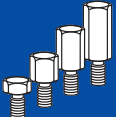
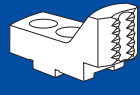
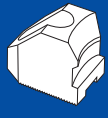
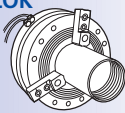
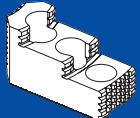

SMW-AUTOBLOK Berg Forkardt Geiger + Haag Röhms Schunk

<p>MHB-D Harte Aufsatzbacken</p>	<p>MHB-D</p>  <p>Seite 28</p>	
<p>GG-D Harte Greifbacken für Außen- und Innenspannung</p> <p>ALB Auflagebolzen</p>	<p>GG-D</p>  <p>Seite 30</p>	<p>ALB</p>  <p>Seite 31</p>
<p>GSG-D Harte Stangen-Greifbacken</p> <p>GFB-D Harte Aufsatzbacken zu Greierfutter GF 80 SMW-AUTOBLOK Röhms</p>	<p>GSG-D</p>  <p>Seite 32</p>	<p>GFB-D</p>  <p>Seite 33</p>
<p>MHB-D Harte Aufsatzbacken für pneumatische Vorderendfutter SMW-AUTOBLOK SMW Röhms Schunk</p> 	<p>MHB-D</p>  <p>Seite 34</p>	

Harte, umkehrbare Aufsatzbacken

MHB-D

Spitzverzahnung Zoll
1/16" x 90° bzw. 3/32" x 90°

Spannkontur und Auflage geschliffen,
Spitzverzahnung geschliffen

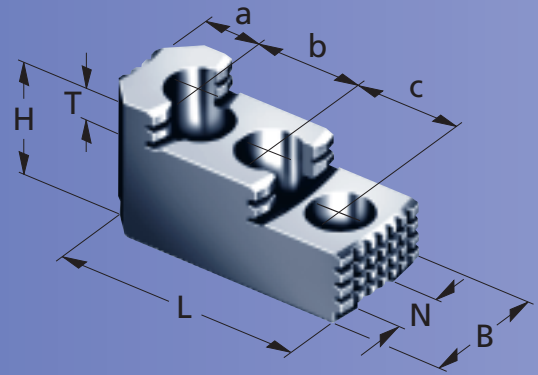

Typ	Id.-Nr.	B	H	L	T	N	Spitz- verzahnung	a + b + c f. DIN 912	kg/ Satz	SMW-AUTOBLOK	SMW	Autoblok
MHB-D 110	007076	20	31	48	7	8	1/16" x 90°	9,5 + 12 + 12 M6	0,6	HFKN-D 110		
MHB-D 130	12081306	30	34	58	8,5	12	1/16" x 90°	13 + 16 + 16 M8	0,6	PB-D/PBI-D 130 BH-D 130 AN-D/AL-D 125 HB-D 130 SP 125 ab Bj. 98	KDV 130	ODN 125 GHDN 125
MHB-D 160	12081636	34	39	65	10	14	1/16" x 90°	18 + 16 + 16 M10	0,9	HFKN-D 165 AN-/AL-D 165 BH-D 165 BHD-FC 165 BB-D 175 PB-D 165 HB-D 165 PBI-D 165 SP 160-38 • STP 160 HYDN-S 180	SP 160 STP 160	GHD-FC 165 GHDN 165
MHB-D 200	12082036	40	45	82	10,5	17	1/16" x 90°	19 + 23 + 23 M12	1,71	HFKN-D 210 SP 200 • STP 200 AN-D/AL-D 210 BHD 210 BB-D 210 BHD-FC 210 HB-D 210 RC-D 210 PB-D/PBI-D 210 HYDN-S 210/226	KDV 200/250 KDVG 200/250 KFV 200 HFK/HFKS 160/200 KFMF 200	ODL 200 ODN 200/220/250 S HDL 200 HDN 200/220/250 S GHD/FC 210 GHDN 210 HDB 220 CD 200 210 RCD
MHB-D 251	12083036	45	56	105	13,5	21	1/16" x 90°	26 + 30 + 30 M16	2,85	HFKN-D 260/315 SP 250/315 ab Bj. 98	KDV 315/400 KDVG 315/400	ODL 250/315/400 ODN 250/315/400
MHB-D 315	12083186	45	56	122	13,5	21	1/16" x 90°	43 + 30 + 30 M16	4,05	AN-D/AL-D 250/315 BH-D 250/315 BHD-FC 250/315 BB-D 250/315 PB-D 250/315 PBI-D 250/315 HB-D 250/315 SP 280/350 STP 280 GH-D 400 HYDN-S 250/315 RC-D 400	KFV 250/315 HFK/HFKS 250/270/315 KFMF 250/315	HDL 250/315/400 HDN 200/315/400 GHD/FC 250/305/400 GHDN 250/315/400 HDB 300 CD 250/315-65/315-85 250 RCD 305 RCD
MHB-D 401	12084006	55	73	120	22	21	1/16" x 90°	30 + 34 + 34 M16	5,1			
MHB-D 500 ¹	12085046	55	73	145	32	25,5	3/32" x 90°	46 + 38 + 38 M20	6,6	HFKN-D 400/500 BB-N 400/460/500 ab Bj. 98 AN-D/AL-D 400 GH-D 500/610/800 BHD-FC 500/630 IN-D 500/630/800 BH-D 400/500	KDV 500 KDVG 500 KFV 400/500/630/800 HFK/HFKS 400/500	
MHB-D 610	12086346	70	75	145	32	25,5	3/32" x 90°	46 + 38 + 38	9			

¹ nur 1 Spannstufe

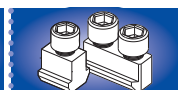

Seite 35
Seite 140

ab Seite 56



Für höchste Spanniederholgenauigkeit empfehlen wir, die Spannbacken **zusätzlich** auf dem Futter unter Spanndruck auszuschleifen.

Berg	Forkardt	Geiger + Haag	Röhm	Schunk
KF 3/130	3 KTH 130-33 3 KTH 140-37	GHGY 120 - 130 GHGY 160 - 200	KFD 130 KFH 140 KFD-HS 160/175	HSG 160 ROTA NC-D 160
			LVE 160	TP 160 ROTA NCO 165 * ROTA NCO F 165 *
KF 3/160 KF 3/200 HES 160 HES 200 HESF 160 HESF 200 KHFF 200	3 KGH 200 • KG 200 KP 200 • 3 KGHF 200 KS 200/250 • KL 200 • KSF 200 KSH 200 • KSHF 200 • KTN 200 KTG 200 • 3 KTGF 200 KSPS 200 • UVE 200/250 KLNC 200 • KL 250 • KS 250 3 NH 200 • 3 NHF 200 QLC 175/210	GHL 200 • GHN 200 GHSH 200 GHHFA 200/250 GHKS 200/250 GHHL 200/250 GHBF 190/210-225 GHGY 250/300 GHL 250 MO GHSP/GHHSP 300	KFD 200 • KFD-H 200 KFD-HF 200 • KFD-HS 200 KFH 200 KFH-F 200 KFH-G 200 KFH-NC 200 KFL 250 SPD 215 SPO 215 LVE 200	TH 165/210 THF 165/210 HSL 165/200 ROTA NC-D 200 ROTA NC-O 200 ROTA NC 210 ROTA NCF 210 TP 200
KF 3/250 KF 3/315 HES 250 HES 315 HESF 250 HESF 315 KHFF 250 KHFF 315	KG 250/315 KP 250/315 KS 315/400 KSH 250/315/400 KTG 250/315 3 KTGF 250/315 KL 250 KSPS 250/300 KNT 250/315 KSHF 250/315/400 UVE 315 KLNC 250/315 3 NH 250/315 QLC 250/315	GHN 250/315 GHSH 250/315 GHKS 315 GHL 250/280 GHHL 280 GHSP/GHHSP 300	KFD 250/315 KFD-HF 250/315 KFD-HS 315 KFH 250/315 KFH-F 250/315 KFH-G 250/315 KFH-NC 250/315 KFL 315/400 SPD 300 SPO 300 LVE 305/315	TH 250/315 THF 250/315 HSL 250/315 ROTA NC-D 250/315 ROTA NC-O 250/315 ROTA NC 250/315 ROTA NCF 250/315 TP 250/315
KF 3/400 KF 3/500 KF 3/630 HES 400 HES 500 HES 630 KHFF 400	KL 400/500 • KL-NC 400/500 KSHF 630 • KS 500/600 • KSL 630 KSH 500 • KS-PS 400 • KG 400/500 UVE 400/500/630/800 KP 400 • 3 KTG 400/500 3 KTGF 400/500 • 3 KTN 400/500 3 NH 400/500/630 3 NHF 400/500/630 QLC 400		KFD 400/500/630/800 KFD-HF 400/500 KFD-HS 400/500 KFH 400/500 KFH-F 400/500 KFH-G 400/500 KFH-NC 400/500 KFL 500/630 LVE 400/500/630/800/1000 Typ 525	TH 400/500 THF 400/500 HSG 400/500 HSL 400 ROTA NC-D 400 ROTA NC-O 400 ROTA NC 400/500 ROTA NCF 400/500

Harte Greifspanbacken

GG-D

für Außen- und Innenspannung

Spitzverzahnung Zoll
1/16" x 90° bzw. 3/32" x 90°

Spitzverzahnung geschliffen

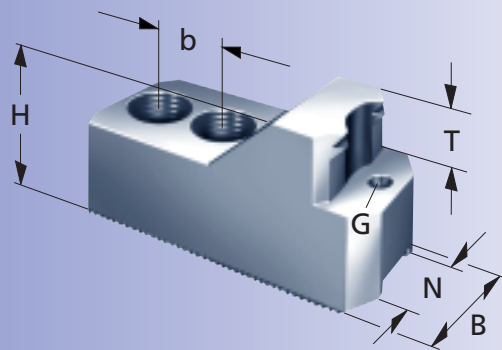

Typ	Id.-Nr.	Außen- spannung	Innen- spannung	B	H	T	G	N	Spitzver- zahnung	b	kg/ Satz	SMW- AUTOBLOK	SMW	Autoblok
GG-D 004	081050	47-68	110-128	35	40	20	6	12	1/16" x 90°	16	1,2	AN-D 125	KDV 130	GHDN 125
GG-D 005	081051	67-88	92-111								1,2	AL-D 125		ODN 125
GG-D 006	090803	87-102	74-93								1,3	BH-D 130		
GG-D 001	081047	25-40	-	35	40	20	M6	12	1/16" x 90°	16	1,2			
GG-D 002	081048	40-60	-								1,2			
GG-D 003	081049	60-80	-								1,1			
GG-D 004	081050	80-100	-								1,2			
GG-D 005	081051	100-120	127-146								1,2			
GG-D 006	090803	120-140	109-127								1,3			
GG-D 007	090804	-	90-109								1,3			
GG-D 010	090732	25-50	-	35	45	20	M6	14	1/16" x 90°	16,5	1,2	HFKN-D 165	SP 160	GHD-FC 165
GG-D 011	090733	49-80	145-185								1,2	AN-D 165 • AL-D 165		GHDN 165
GG-D 012	090734	80-120	115-145								1,1	BH-D 165		
GG-D 013	090735	119-150	80-115								1,3	BHD-FC 165		
GG-D 014	090736	-	50-80								1,2	BBD 175 • SP 160 HYDN-S 180		
GG-D 020	081052	40-60	-	35	50	25	M6	17	1/16" x 90°	22	1,2		KDV 160	
GG-D 021	081053	60-80	168-188								1,2		KDVG 160	
GG-D 022	081054	80-100	144-164								1,1		KFV 160	
GG-D 023	081055	100-120	125-145								1,2		KFMF 160	
GG-D 024	081056	120-140	105-125								1,3		HFV 160	
GG-D 025	090808	-	86-105								1,2		HFV 160	
GG-D 026	090809	-	67-86								1,1		HFV 160	
GG-D 030	081057	30-60	-	35	50	25	M6	17	1/16" x 90°	22	1,2	HFKN-D 210	KDV 200	CD 200
GG-D 031	081058	60-90	210-240								1,2	AN-D 210 • AL-D 210	KDVG 200	GHD-FC 210
GG-D 032	081059	90-120	180-210								1,2	RC-D 210	KFV 200	HDL 200 • HDN 200
GG-D 033	081060	120-150	150-180								1,3	BH-D 210	KFMF 200	GHDN 210
GG-D 034	090811	-	120-150								1,2	BHD-FC 210	HFV 200	ODL/ODN 200
GG-D 035	090812	-	90-120								1,3	SP 200 HYDN-S 210/226	HFV 200	RCD 210
GG-D 030	081057	40-80	-	35	50	25	M6	17	1/16" x 90°	22	1,2		KDV 250	HDN 220
GG-D 031	081058	80-120	210-290								1,2		KDVG 250	ODN 220
GG-D 032	081059	120-160	175-250								1,2			HDB 220
GG-D 033	081060	160-200	140-210								1,3			
GG-D 034	090811	-	120-160								1,2			
GG-D 035	090812	-	90-130								1,3			
GG-D 050	081065	40-80	-	45	59	28	M8	21	1/16" x 90°	28	2,5	AN-D 250	KFV 250	RCD 250
GG-D 051	081066	80-120	250-300	45							2,5	AL-D 250	KFMF 250	GHD-FC 250
GG-D 052	081067	120-160	220-260	60							2,6	BH-D 250	HFV 250	HDL/HDN 250
GG-D 053	081068	160-210	180-225	60							3,3	BHD-FC 250	HFV 250	GHDN 250
GG-D 054	090817	200-250	140-180	60							3,6	SP 250/280	HFV 270	ODL/ODN 250
GG-D 055	090818	-	100-150	60							3,4	HFKN-D 260		
GG-D 056	090819	-	60-100	45	15						3,4	HYDN-S 250		
GG-D 060	081069	50-110	-	45	59	28	M8	21	1/16" x 90°	28	3,6	AN-D 315	KDV 315	
GG-D 061	081070	100-170	280-350	60							3,5	AL-D 315	KDVG 315	
GG-D 062	080552	150-220	240-290	60							3,5	BH-D 315	KFV 315	
GG-D 063	081071	210-290	175-250	60							3,6	BHD-FC 315	KFMF 315	
GG-D 064	090820	280-350	120-180	60							3,5	BHD-FC 400	HFV 315	
GG-D 065	090821	-	65-120	45	15						3,4	SP 315 • SP 350 HFKN-D 315 HYDN-S 315	HFV 315	
GG-D 080	081076	100-160	-	60	80	40	M8	25,5	3/32" x 90°	35	9,6	AN-D 400	KDV 500	
GG-D 081	019355	160-240	-								7,7	AL-D 400	KDVG 500	
GG-D 082	081077	240-320	270-380								7,1	HFKN-D 400/500	KFV 400/500	
GG-D 083	081078	320-400	190-290								8,4	BH-D 400/500	KFV 630/800	
GG-D 084	081079	350-460	140-230								9,1	BHD-FC 500	HFV 400	
GG-D 085	081080	-	090-150		65	25					9,0	BHD-FC 630 IL-D 500 • IL-D 630 IL-D 800 • GH-D 500 GH-D 610 • GHD 640 GH-D 800	HFV 400 HFV 500 HFV 500	

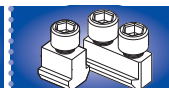

Auflagebolzen

ALB

Typ	Id-Nr.	G	H	SW
ALB 605	016513	M6	5	10
ALB 610	016511		10	
ALB 615	016512		15	
ALB 620	017602		20	
ALB 805	017603	M8	5	13
ALB 810	016514		10	
ALB 815	016515		15	
ALB 820	016516		20	
ALB 825	081191		25	

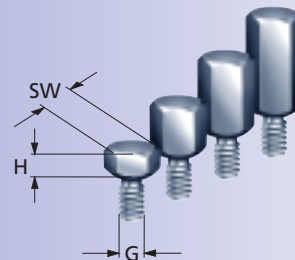

Berg	Forkardt	Geiger + Haag	Röhm	Schunk
KF 3/130	3 KTH 130 3 KTH 140	GHGY 120/130	KFD 130 KFD 140	
		GHGY 160/200	KFD-HS 160 KFD-HS 175	HSG 160
				TP 160 ROTA-NCO 165 * ROTA-NCO F 165 *
HES 160 KF 3/160	3 KGH/KGHF 160/175 KL 160 • KSF 175 • KSH 160 KS/KSPS 160 • UVE 160 KTG 160 • KTN 160 3 KTH 160/175 NHF 160 • QLC 175	GHN 160 GHL 160 GHHL 160 GHKS 160 GHSH 160 GHFA 175	KFD 160 • KFD-H 160 KFD-HF 160 • KFH 160 KFH 170 • KFH-F 160 KFH-G 160 • KFH-NC 160 SPD 160 • SPO 160	TH 165 THF 165 HSL 165 ROTA-NC 165 ROTA-NCF 165
HES 200 HESF 200 KF 3/200 HESF 200 KHFF 200	3 KGH/KGHF 200 KG/KL/KLNC/KP 200 KS/KSPS 200 • UVE 200 KSH/KSHF 200 • KSF 200 • KTN 200 KTG 200 • 3 KTGF 200 • 3 KTH 200 3 NH 200 • 3 NHF 200 • QLC 210	GHN 200 GHL 200 GHHL 200 GHHFA 200 GHKS 200 GHSH 200	KFD 200 • KFD-HS 200 KFD-H 200 KFD-HF 200 • KFH 200 KFH-F 200 • KFH-G 200 KFH-NC 200 SPD 215 • SPO 215	TH 210 THF 210 HSG 200 • HSL 210 TP 200 ROTA-NC 210 ROTA-NCF 210
	KL 250 KS 250 UVE 250 NHF 250-65 (Index)	GHL 250 Mo GHHFA 250 GHKS 250	KFL 250 KFD-HS 250	HSG 250
	KG/KP/KS/KSH 250 KL/KLNC 250 • KTN 250 3 NH/NHF 250 • 3 KTGF 250 KTG 250 • KSPS 250 KSHF 250 QLC 250	GHN 250 GHSH 250	KFD 250 • KFD-H 250 KFD-HF 250 KFH 250 • KFH-F 250 KFH-G 250 • KFH-NC 250	TH 250 THF 250 HSL 250 TP 250 ROTA-NC 250 ROTA-NCF 250
	KG/KP/KS/KSH 315 KTG 315 • 3 KTGF 315 KSPS 300 • KTN 315 KSHF 315 • KLNC 315 3 NH 315 • 3 NHF 315 UVE 315 • QLC 315	GHN 315 GHKS 315 GHSH 315	KFD 315 • KFD-H 315 KFD-HF 315 • KFD-HS 315 LVE 305 • KFL 315 • KFH 315 KFH-F 315 • KFH-G 315 KFH-NC 315 • SPD/SPO 300	TH 315 THF 315 HSG 315 HSL 315 ROTA-NC 315 ROTA-NCF 315
	KG 400/500 • KP 400 KL/KLNC 400/500 KS 500/630 • KSL 630 KSH 500 • KSHF 630 • KSPS 400 UVE 400/500/630/800 3 KTG/KTGF 400/500 3 KTF 400/500 3 KTN 400/500 3 NH 400/500/630 3 NHF 400/500/630 • QLC 400		KFD 400/500 • KFD-H 400 KFD-HF 400 • KFD-HS 400 KFH 400 • KFH-F 400 KFH-G 400 • KFH-NC 400 LVE 400/500/630 KFD-H 500 • KFD-HF 500 KFD-HS 500 • KFH 500 KFL 500 • KFH-F 500 KFH-G 500 • KFH-NC 500 KDF 630 • KFL 630	HSG 400/500 THF 400/500 HSL 400 TH 400/500 ROTA-NC 400/500 ROTA-NCE 400/500

Harte Stangengreifbacken

GSG-D

Spitzverzahnung Zoll
1/16" x 90° bzw. 3/32" x 90°

Spitzverzahnung geschliffen

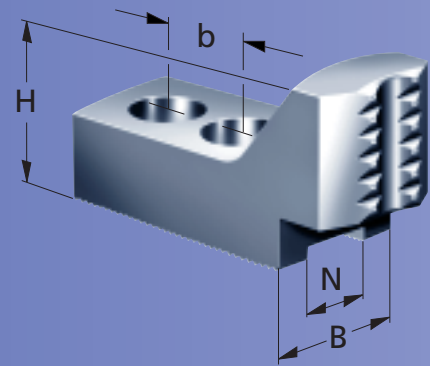

Typ	Id.-Nr.	Spannbereich Ø	B	H	N	Spitzverzahnung	b für DIN 912	kg/Satz	SMW-AUTOBLOK	SMW	Autoblok
GSG-D 165	091343	15-40	30	40	14	1/16" x 90°	22 M10	1,2	HFKN-D 165 AN-D 165 * AL-D 165 * BH-D 165 * BHD-FC 165 * BB-D 175 * PB-D 165 * HB-D 165 * PBI-D 165 * SP 160-38 STP 160 HYDN-S 180 *	SP 160 STP 160	GHD-FC 165 GHDN 165
GSG-D 200	091344	15-50	40	40	17	1/16" x 90°	22 M12	1,5	HFKN-D 210 SP 200 STP 200 AN-D/AL-D 210 BHD 210 BB-D 210 BHD-FC 210 HB-D 210 RC-D 210 PB-D/PBI-D 210 HYDN-S 210/226	KDV 200/250 KDBG 200/250 KFV 200 HFK/HFKS 200 KFMF 200	ODL 200 ODN 200/220 HDL 200 HDN 200/220 GHD/FC 210 GHDN 210 HDB 220 CD 200 210 RCD
GSG-D 250	091345	20-80	50	50	21	1/16" x 90°	28 M16	3,5	HFKN-D 260/315 SP 250/315 ab Bj. 98 AN-D/AL-D 250/315 * BH-D 250/315 * BHD-FC 250/315 * BB-D 250/315 * PB-D 250/315 * PBI-D 250/315 * HB-D 250/315 * SP 280/350 STP 280 HYDN-S 250/315 *	KDV 315/400 KDBG 315/400 KFV 250/315 HFK/HFKS 250/270/315 KFMF 250/315	ODL 250/315/400 ODN 250/315/400 HDL 250/315/400 HDN 200/315/400 GHD/FC 250/305/400 GHDN 250/315/400 HDB 300 CD 250/315-65/315-85 250 RCD 305 RCD
GSG-D 400	091346	40-100	60	60	25,5	3/32" x 90°	35 M20	8,0	HFKN-D 400/500 BB-N 400/460/500 ab Bj.98 AN-D/AL-D 400 GH-D 500/610/800 BHD-FC 500/630 IN-D 500/630/800	KDV 500 KDBG 500 KFV 400/500/630/800 HFK/HFKS 400/500	
GFB-D 1	016348	5-25	25	39	10	1/16" x 90°	M8		GF 80		
GFB-D 2	016349	25-45	30								
GFB-D 3	016350	45-65									
GFB-D 4	016351	65-80									
GFB-D 5	016352	80-100									

* nur mit Einzelnutenstein

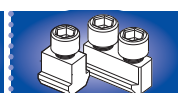

Seite 35
Seite 140

ab Seite 56

Harte Aufsatzbacken

GFB-D

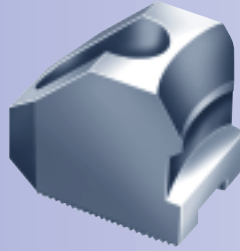

Spitzverzahnung Zoll
1/16" x 90° bzw. 3/32" x 90°

Spitzverzahnung geschliffen

Berg	Forkardt	Geiger + Haag	Röhm	Schunk
				TP 160 ROTA NCO 165 * ROTA NCO F 165 *
KF 3/200 HES 200 HESF 200 KHFF 200	3 KGH 200 3 KGHF 200 KG 200 • KP 200 KS 200/250 • KL 200 KSPS 200 • KSF 200 KTG 200 • KTN 200 KTGF 200 • 3 KTH 200 3 NHF 200 • 3 NH 200 KSHF 200 • KSH 200 KLNC 200 • UVE 200/250 QLC 210	GHL 200 GHN 200 GHS 200 GHHFA 200/250 GHKS 200/250 GHHL 200/250 GHB 190/210/225 GHL 250 MO GHSP 215 GHHSP 215	KFD 200 KFD-HF 200 KFH 200 KFH-F 200 KFH-G 200 KFH-NC 200 SPD 215 SPO 215	TH 210 THF 210 HSL /210 TP 200 ROTA NC-O 200 ROTA NC 210 ROTA NCF 210
KF 3/250 KF 3/315 HES 250 HES 315 HESF 250 HESF 315 KHFF 250 KHFF 315	KG 250/315 • KP 250/315 KS 315/400 • KSH 250/315/400 KTG 250/315 3 KTGF 250/315 KL 250 • KSPS 250/300 KNT 250/315 KSHF 250/315/400 KLNC 250/315 • UVE 315 3 NH 250/315 QLC 250/315	GHN 250/315 GHS 250/315 GHKS 315 GHL 250/280 GHHL 280 GHSP/GHHSP 300	KFD 250/315 KFD-HF 250/315 KFH 250/315 KFH-F 250/315 KFH-G 250/315 KFH-NC 250/315 KFL 315/400 LVE 250 • LVE 305 SPD 300 • SPO 300	TH 250/315 THF 250/315 HSL 250/315 ROTA NC-D 250/315 ROTA NC-O 250/315 TP 250/315 ROTA NC 250/315 ROTA NCF 250/315
KF 3/400 KF 3/500 KF 3/630 HES 400 HES 500 HES 630 KHFF 400	KL 400/500 • KL-NC 400/500 KSHF 630 • KS 500/600 KSL 630 • KSH 500 KS-PS 400 • KG 400/500 UVE 400/500/630/800 KP 400 • 3KTG 400/500 3 KTGF 400/500 3 KTN 400/500 3 NH 400/500/630 3 NHF 400/500/630 QLC 400		KFD 400/500/630/800 KFD-HF 400/500 KFD-HS 400/500 KFH 400/500 KFH-F 400/500 KFH-G 400/500 KFH-NC 400/500 KFL 500/630 LVE 400/500/630/1000	TH 400/500 THF 400/500 HSG 400/500 HSL 400 ROTA NC-400 ROTA NC-O 400 ROTA NC 400/500 ROTA NCF 400/500
			GF 80	

Harte, umkehrbare Aufsatzbacken für Vorderend-Kraftspannfutter

MHB-D

Spitzverzahnung Zoll
1/16" x 90° bzw. 3/32" x 90°

Spitzverzahnung geschliffen

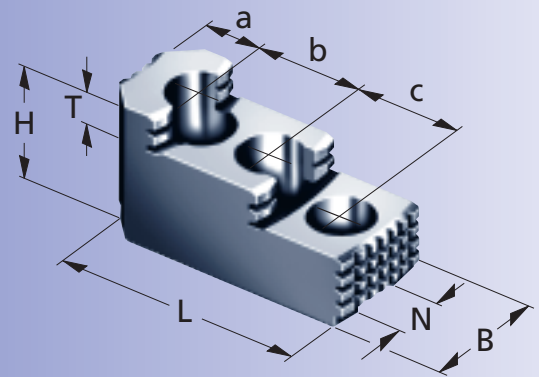

Typ	Id.-Nr.	B	H	L	T	N	Spitz- verzahnung	a + b + c f. DIN 912	kg/ Satz	SMW- AUTOBLOK	SMW	Röh- m	Sch- unk
MHB-D 125	013817	24	40	58	9	11	1/16" x 90°	9,5 + 18 + 18 M8	0,7		SP 125-26 STP 125 STWP 125	LV 125	TP 125-26
MHB-D 130	12081306	30	34	58	8,5	12	1/16" x 90°	13 + 16 + 16 M8	0,6	SP 125-26 ab Bj. 98 STP 125 ab Bj. 98			
MHB-D 160	12081636	34	39	65	10	14	1/16" x 90°	18 + 16 + 16 M10	0,9	SP 160-38 STP 160	SP 160-38 STP 160 STWP 160	LVE 160	TP 160-38
MHB-D 200	12082036	40	45	82	10,5	17	1/16" x 90°	19 + 23 + 23 M12	1,7	SP 200-52 STP 200	SP 200-52 LP 205 STP 200 STWP 200	LVE 200	TP 200-52
MHB-D 250	013820	44	58	108	14	21	1/16" x 90°	26 + 30 + 30 M14	3,3		SP 250-68 • LP 250 STP 250 • STWP 250 SP 315-90 • SP 315-105 LP 305 • STP 315-90 STP 315-105 STWP 315-105	LVE 250 LVE 315	
MHB-D 251	12083036	45	56	105	13,5	21	1/16" x 90°	26 + 30 + 30 M16	2,85	SP 250-68 ab Bj. 98 SP 280 STP 250 ab Bj. 98		LVE 305	TP 250
MHB-D 315	12083186	50	56	122	13,5	21	1/16" x 90°	43 + 30 + 30 M16	4,05	SP 350-115		LVE 315	TP 315
MHB-D 400	013822	57	73	160	22	25,5	3/32" x 90°	40 + 42 + 42 M18	9,6		BB 400 • BB 400 ES STP 400/500 • BB 500 LP 380 • LP 460 LP 500 • BB 500 ES BB 630-265 ES	LVE 400/500	TB 400 TB 500 TB 630-265 LH
MHB-D 500 ¹	12085046	55	73	145	32	25,5	3/32" x 90°	46 + 38 + 38 M20	2,2	BB-N 400-140 BB-N 460-175 BB-N 500-205 BB-N 500-630		LVE 400/500/630/ 800/1000 Typ 525	
MHB-D 630 ¹	12086446	75	85	160	30	30	3/32" x 90°	30 + 50 + 50 M24	4,5	BB-N 630-310			TB 630 TB 630-265 TB 630-325 LH
MHB-D 800 ¹	12088046	75	85	220	30	30	3/32" x 90°	51 + 62 + 62 M24	6,5	BB-N 800-410 BB-N 1000-534			TB 800 TB 1000 TB 850-375 LH TB 1000-560 LH

¹ nur 1 Spannstufe

