

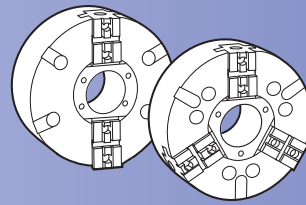

Weiche Aufsatzbacken

Stahl ■ Aluminium

Kreuzversatz

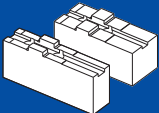
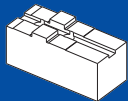
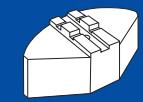
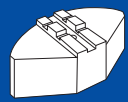
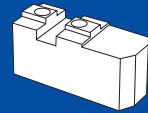
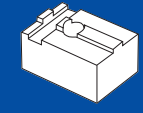
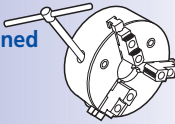
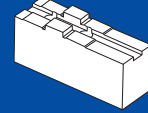

SMW-AUTOBLOK Berg Forkardt Geiger + Haag Kitagawa Röhm Schunk

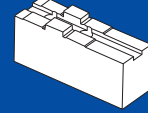
<p>WAK WAKS WAK-A</p>	<p>Weiche Aufsatzbacken 16MnCr5 Weiche Aufsatzbacken 16MnCr5 Alu-Aufsatzbacken Aluminium F50</p>	<p>Standard breit</p>	<p>WAK, WAKS</p>  <p>Seite 72</p>	<p>WAK-A</p>  <p>Seite 74</p>
<p>SBK SBK-A</p>	<p>Weiche Segmentbacken 16MnCr5 Alu-Segmentbacken Aluminium F50</p>		<p>SBK</p>  <p>Seite 75</p>	<p>SBK-A</p>  <p>Seite 76</p>
<p>WBR</p>	<p>Weiche Aufsatzbacken 16MnCr5</p>		<p>WBR</p>  <p>Seite 77</p>	
<p>WBK</p>	<p>Weiche Aufsatzbacken 16MnCr5</p>		<p>WBK</p>  <p>Seite 78</p>	
<p>WA-RN</p>	<p>Weiche Aufsatzbacken 16MnCr5</p>	<p>Handspannfutter Amestra Ladner Pratt-Burned Röhm</p> 	<p>WA-RN</p>  <p>Seite 79</p>	
<p>WAKA</p>	<p>Weiche Aufsatzbacken C45</p>	<p>alle Futter American Standard</p> 	<p>WAKA</p>  <p>Seite 80</p>	

Weiche Aufsatzbacken

WAK für Backenschnellwechsel

Kreuzversatz

Werkstoff: 16MnCr5

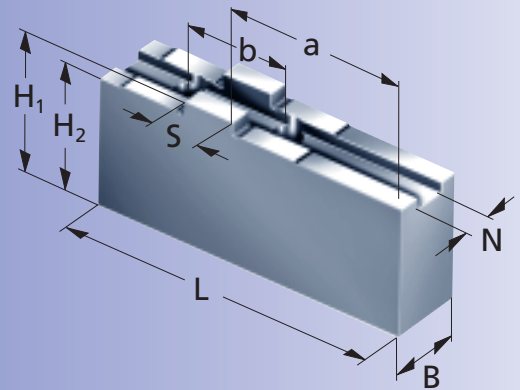

Typ	Id.-Nr.	B	H ₁	H ₂	L	N	S	a	b	kg/ Satz	SMW- AUTOBLOK	SMW	Berg	Forkardt	Kitagawa	Röhms	Schunk
WAK 125-10	016633	20	30	27,5	55	14 (Nut)	5 (Nut)	25	20	0,6		RMG 125		F 125 F+125		Duro 125	
WAK 140-10	012490	20	40	35,5	69	8	18	26	32	0,9	KNCS-N 140	KNCS 140				Duro-NC 140 Duro-NC 168	
WAK 160-10	012491	20	40	35,5	85	8	18	42	32	1,2	HG-N 160 HG-F 160 KNCS-N 170	RMG 160 HG 160 KNSP 160 KNCS 160 KNCS 175	KHNC 160 KHNC 185	F 160 KTNC 160 KTNCV 160 KTNCV 175 FNC 175 F+160		Duro 160 Duro-NC 160 Duro-NC 175 Duro-NCE 160	ROTA-S 160 THW 165 ROTA-G 160 ROTA NC-W 185 ROTA-S PLUS 160
WAK 200-10	012492	22	46	42	105	10	20	50	40	2,0	HG-N 210 HG-F 210 KNCS-N 210 KNCS-N 225 KNCS-NB 210	RMG 200 HG 200 KNSP 200 KNCS 200 KNCS 210	KHNC 200	F 200 KTNC 200 KTNCV 200 FNC 200 F+200	QJ 8" (QJ 210-43)	Duro 200 Duro-NC 200 Duro-NC 225 Duro-NCE 200	ROTA-S 200 THW 210-F/R THWB 210 ROTA-G 200 ROTA-NC-W 225 ROTA-S PLUS 200 ROTA-NC-WF 210
WAK 250-10	012493	30	55	50	125	12	20	70	40	3,6	HG-N 260 HG-N 315 HG-F 260 KNCS-N 260 KNCS-N 315 KNCS-NB 260 KNCS-NB 315	RMG 250 HG 250 HG 315 KNCS 250 KNCS 260 KNCS 315	KHNC 250 KHNC 315	F 250 UNC 250/315 KTNC 250 KTNCV 250 KTNC 265 KTNC 280 KTNC 315 KTNCV 315 FNC 250 FNC 315 F+250	QJ 10" (QJ 254-65) QJ 12" (QJ 315-78)	Duro 250 Duro-NC 250 Duro-NCE 250	ROTA-S 250 ROTA-G 250 THW 250-F/R THW 265-F/R THW 315 R THWB 265 ROTA NC-WF 250 ROTA-S PLUS 250 ROTA NC-W 265 ROTA-G 315 ROTA NC-W 315 ROTA-NC-WF 315
WAK 400-10	012494	35	60	54	145	12	26	74	54	5,8	HG-N 400 HG-F 315 KNCS-N 400 KNCS-NB 400	RMG 315 HG 400 KNCS 400	KHNC 400	F 315 UNC 400 KTNC 360 KTNC 400 KTNCV 400 FNC 400 F+315		Duro 315 Duro-NC 315 Duro-NCE 400	ROTA-S 315 THW 315 F THW 400-F/R THWB 315 ROTA-S PLUS 315 ROTA-G 400 ROTA NC-W 400
WAK 500-10	012495	45	80	73	180	18	30	100	60	13,7	HG-N 500 HG-N 630 HG-F 400 HG-F 500 KNCS-N 500 KNCS-N 630 KNCS-NB 500 KNCS-NB 630 KNCS-NB 800	HG 500 HG 630 KNCS 500 KNCS 630	KHNC 500	F 400/500 L UNC 500 KTNC 500/630 KTNCV 500/630 FNC 500/630 F+400 F+500L		Duro 400 Duro-NC 400 Duro 500 Duro-NC 500 Duro-NCE 500	ROTA-S 400 ROTA-S 500 THW 500-F/R THW 630-R THWB 400 ROTA-S PLUS 400 ROTA-S PLUS 500 ROTA-G 500
WAK 630-10	080930	60	120	112	260	24	40	149	82	28,5	HG-F 630			F 630			ROTA-S 630 ROTA-S PLUS 630 ROTA-G 630

Andere Abmessungen sind ebenfalls lieferbar.
Als Bestellhilfe kann eine Kopie des Maßblattes auf Seite 81 verwendet werden.

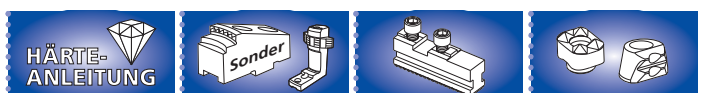

Seite 147

Seite 81
Seite 95
Seite 140

Seite 98
Seite 120

Seite 66

Weiche Aufsatzbacken breite Ausführung

WAKS für Backenschnellwechsel

Kreuzversatz

Werkstoff: 16MnCr5

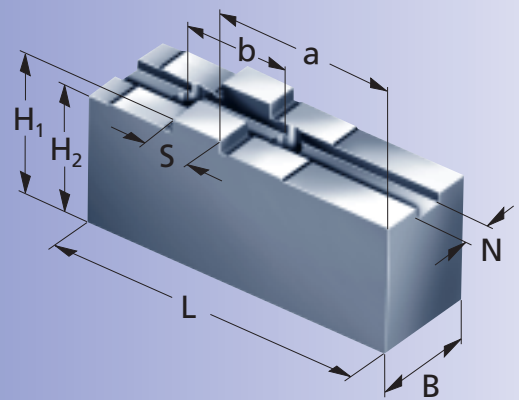

Typ	Id.-Nr.	B	H ₁	H ₂	L	N	S	a	b	kg/ Satz	SMW- AUTOBLOK	SMW	Berg	Forkardt	Kitagawa	Röhms	Schunk
WAKS 140-10	012496	35	40	35,5	63	8	18	25	32	1,5	KNCS-N 140	KNCS 140				Duro-NC 140 Duro-NC 168	
WAKS 160-10	080931	25	50	45,5	85	8	18	42	32	1,8	HG-N 160	RMG 160	KHNC 160	F 160		Duro 160	ROTA-S 160
WAKS 160-20	080932	30	55	50,5	85			48	32	2,2	HG-F 160	HG 160	KHNC 185	KTNC 160		Duro-NC 160	THW 165
WAKS 160-30	080933	35	80	75,5	70			26	32	3,4	KNCS-N 170	KNSP 160 KNCS 160 KNCS 175		KTNCV 160 KTNCV 175 FNC 175 F+160		Duro-NC 175 Duro-NCE 160	ROTA-G 160 ROTA NC-W 185 ROTA-S PLUS 160
WAKS 200-10	080934	30	55	51	100	10	20	57	40	2,9	HG-N 210	RMG 200	KHNC 200	F 200	QJ 8"	Duro 200	ROTA-S 200
WAKS 200-20	080935	30	70	66	100			45	40	3,4	HG-F 210	HG 200		KTNC 200	(QJ 210-43)	Duro-NC 200	THW 210-F/R
WAKS 200-30	012497	40	40	36	70			27	40	1,9	KNCS-N 210	KNSP 200		KTNCV 200		Duro-NC 225	THWB 210
WAKS 200-31	080936	40	60	56	90			43	40	3,9	KNCS-N 225	KNCS 200		FNC 200		Duro-NCE 200	ROTA-G 200
WAKS 200-32	036733	40	80	76	95			52	40	5,8	KNCS-NB 210	KNCS 210		F+200			ROTA-NC-W 225 ROTA-S PLUS 200 ROTA-NC-WF 210
WAKS 250-10	080937	40	60	55	125	12	20	70	40	3,9	HG-N 260	RMG 250	KHNC 250	F 250	QJ 10"	Duro 250	ROTA-S 250
WAKS 250-11	080938	40	80	75	125			70	40	7,5	HG-N 315	HG 250	KHNC 315	UNC 250/315	(QJ 254-65)	Duro-NC 250	ROTA-G 250
WAKS 250-12	080939	40	100	95	125			70	40	9,6	HG-F 260	HG 315		KTNC 250	QJ 12"	Duro-NCE 250	THW 250-F/R
WAKS 250-13	080940	40	120	115	125			70	40	11,5	KNCS-N 260	KNCS 250		KTNCV 250	(QJ 315-78)	Duro-NCE 315	THW 265-F/R
WAKS 250-20	012498	60	60	55	90			44	40	6,2	KNCS-N 315	KNCS 260		KTNC 265			THW 315 R
WAKS 250-21	080942	60	60	55	110			60	40	7,6	KNCS-NB 260	KNCS 315		KTNC 280			THWB 265
WAKS 250-22	080943	60	80	75	90			44	40	9,4	KNCS-NB 315			KTNC 315			ROTA NC-WF 250
WAKS 250-23	080944	60	80	75	110			60	40	11,5				KTNCV 315			ROTA-S PLUS 250
WAKS 250-30	012499	80	60	55	90			44	40	8,5				FNC 250			ROTA NC-W 265
WAKS 250-31	080945	80	80	75	110			60	40	14,1				FNC 315 F+250			ROTA-G 315 ROTA NC-W 315 ROTA-NC-WF 315
WAKS 400-10	080946	40	60	54	110	12	26	54	54	4,9	HG-N 400	RMG 315	KHNC 400	F 315		Duro 315	ROTA-S 315
WAKS 400-11	080947	40	60	54	145			89	54	6,7	HG-F 315	HG 400		UNC 400		Duro-NC 315	THW 315 F
WAKS 400-12	080948	40	100	94	145			89	54	11,1	KNCS-N 400	KNCS 400		KTNC 360		Duro-NCE 400	THW 400-F/R
WAKS 400-13	080949	40	120	114	145			89	54	13,5	KNCS-NB 400			KTNC 400			THWB 315
WAKS 400-14	080950	40	150	146	145			89	54	16,9				KTNCV 400			ROTA-S PLUS 315
WAKS 400-20	080951	60	60	54	110			54	54	7,6				FNC 400			ROTA-G 400
WAKS 400-21	080952	60	80	74	110			54	54	10,3				F+315			ROTA NC-W 400
WAKS 400-22	080953	60	100	94	110			54	54	14,1							
WAKS 400-30	012500	80	70	64	100			44	54	11,0							
WAKS 500-10	080954	60	80	73	155	18	30	90	60	13,8	HG-N 500	HG 500	KHNC 500	F 400/500 L		Duro 400	ROTA-S 400
WAKS 500-12	080956	60	120	113	155			90	60	19,5	HG-N 630	HG 630		UNC 500		Duro-NC 400	ROTA-S 500
WAKS 500-20	080957	80	80	73	155			90	60	15,5	HG-F 400	KNCS 500		KTNC 500/630		Duro 500	THW 500-F/R
WAKS 500-21	080958	80	100	93	155			90	60	26,3	HG-F 500	KNCS 630		KTNCV 500/630		Duro-NC 500	THW 630-R
WAKS 500-30	012501	90	80	73	130			65	60	16,4	KNCS-N 500			FNC 500/630		Duro-NCE 500	THWB 400
WAKS 500-31	012502	100	80	73	150			85	60	20,0	KNCS-N 630 KNCS-NB 500 KNCS-NB 630 KNCS-NB 800			F+400 F+500			ROTA-S PLUS 400 ROTA-S PLUS 500 ROTA-G 500

Weiche Aufsatzbacken
Kreuzversatz

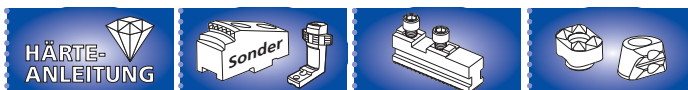

Seite 147

Seite 81
Seite 95
Seite 140

Seite 98
Seite 120

Seite 66

Weiche Aufsatzbacken Alu leichte Ausführung

WAK-A für Backenschnellwechsel

Kreuzversatz

Werkstoff: Aluminium (Festigkeit ca. 500 N/mm²)

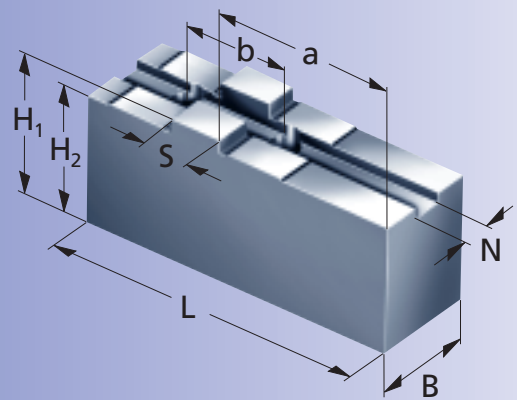

Typ	Id.-Nr.	B	H ₁	H ₂	L	N	S	a	b	kg/ Satz	SMW- AUTOBLOK	SMW	Berg	Forkardt	Kitagawa	Röhms	Schunk
WAK-A 160	080959	25	50	45,5	85	8	18	42	32	0,7	HG-N 160 HG-F 160 KNCS-N 170	RMG 160 HG 160 KNSP 160 KNCS 160 KNCS 175	KHNC 160 KHNC 185	F 160 KTNC 160 KTNCV 160 KTNCV 175 FNC 175 F+160		Duro 160 Duro-NC 160 Duro-NC 175 Duro-NCE 160	ROTA-S 160 THW 165 ROTA-G 160 ROTA NC-W 185 ROTA-S PLUS 160
WAK-A 200	080960	25	50	46	105	10	20	50	40	0,9	HG-N 210 HG-F 210 KNCS-N 210 KNCS-N 225 KNCS-NB 210	RMG 200 HG 200 KNSP 200 KNCS 200 KNCS 210	KHNC 200	F 200 KTNC 200 KTNCV 200 FNC 200 F+200	QJ 8" (QJ 210-43)	Duro 200 Duro-NC 200 Duro-NC 225 Duro-NCE 200	ROTA-S 200 THW 210-F/R THWB 210 ROTA-G 200 ROTA NC-W 225 ROTA-S PLUS 200 ROTA NC-WF 210
WAK-A 210	035222	40	60	56	90	10	20	43	40	1,65							
WAK-A 250	080961	40	60	55	125	12	20	70	40	2,0	HG-N 260 HG-N 315 HG-F 260 KNCS-N 260 KNCS-N 315 KNCS-NB 260 KNCS-NB 315	RMG 250 HG 250 HG 315 KNCS 250 KNCS 260 KNCS 315	KHNC 250 KHNC 315	F 250 UNC 250/315 KTNC 250 KTNCV 250 KTNC 265 KTNC 280 KTNC 315 KTNCV 315 FNC 250 FNC 315 F+250	QJ 10" (QJ 254-65) QJ 12" (QJ 315-78)	Duro 250 Duro-NC 250 Duro-NCE 250 Duro-NCE 315	ROTA-S 250 ROTA-G 250 THW 250-F/R THW 265-F/R THW 315-R THWB 265 ROTA NC-WF 250 ROTA-S PLUS 250 ROTA NC-W 265 ROTA-G 315 ROTA NC-W 315 ROTA NC-WF 315
WAK-A 400	080962	40	60	54	145	12	26	74	54	2,4	HG-N 400 HG-F 315 KNCS-N 400 KNCS-NB 400	RMG 315 HG 400 KNCS 400	KHNC 400	F 315 UNC 400 KTNC 360 KTNC 400 KTNCV 400 FNC 400 F+315		Duro 315 Duro-NC 315 Duro-NCE 400	ROTA-S 315 THW 315-F THW 400-F/R THWB 315 ROTA-S PLUS 315 ROTA-G 400 ROTA NC-W 400
WAK-A 500	035142	50	80	73	180	18	30	100	60	5,1	HG-N 500 HG-N 630 HG-F 400 HG-F 500 KNCS-N 500 KNCS-N 630 KNCS-NB 500 KNCS-NB 630 KNCS-NB 800	HG 500 HG 630 KNCS 500 KNCS 630	KHNC 500	F 400/500 L UNC 500 KTNC 500/630 KTNCV 500/630 FNC 500/630 F+400 F+500		Duro 400 Duro-NC 400 Duro 500 Duro-NC 500 Duro-NCE 500	ROTA-S 400 ROTA-S 500 THW 500-F/R THW 630-R THWB 400 ROTA-S PLUS 400 ROTA-S PLUS 500 ROTA-G 500

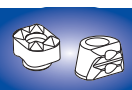
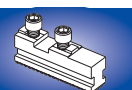

Seite 81
Seite 95
Seite 140

Seite 98
Seite 120

Seite 66

Weiche Segmentbacken

SBK für Backenschnellwechsel

Kreuzversatz

Werkstoff: 16MnCr5

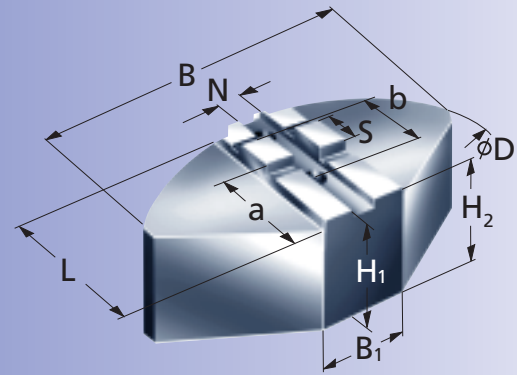

Typ	Id.-Nr.	B	B ₁	H ₁	H ₂	L	N	S	a	b	D	kg/Satz	SMW-AUTOBLOK	SMW	Berg	Forkardt	Kitagawa	Röhmm	Schunk
SBK 160	080963	120	40	50	46	60	8	18	23	32	160	4,5	HG-N 160 HG-F 160 KNCS-N 170	RMG 160 HG 160 KNSP 160 KNCS 160 KNCS 175	KHNC 160 KHNC 185	F 160 KTNC 160 KTNCV 160 KTNCV 175 FNC 175 F+160		Duro 160 Duro-NC 160 Duro-NC 175 Duro-NCE 160	ROTA-S 160 THW 165 ROTA-G 160 ROTA NC-W 185 ROTA-S PLUS 160
SBK 200	080964	140	65	60	56	70	10	20	27	40	200	8,4	HG-N 210 HG-F 210 KNCS-N 210 KNCS-N 225 KNCS 210	RMG 200 HG 200 KNSP 200 KNCS 200 KNCS 210	KHNC 200	F 200 KTNC 200 KTNCV 200 FNC 200 FNC 175 F+200	QJ 8" (QJ 210-43)	Duro 200 Duro-NC 200 Duro-NC 225 Duro-NCE 200	ROTA-S 200 THW 210-F-R THWB 210 ROTA-G 200 ROTA NC-W 225 ROTA-S PLUS 200 ROTA NC-WF 210
SBK 250	080965	180	70	60	55	90	12	20	44	40	250	11,2	HG-N 260 HG-N 315 HG-F 260 KNCS-N 260 KNCS-N 315 KNCS-NB 260 KNCS-NB 315	RMG 250 HG 250 HG 315 KNCS 250 KNCS 260 KNCS 315	KHNC 250 KHNC 315	F 250 UNC 250/315 KTNC 250 KTNCV 250 KTNC 265 KTNC 280 KTNC 315 KTNCV 315 FNC 250 FNC 315 F+250	QJ 10" (QJ 254-65) QJ 12" (QJ 315-78)	Duro 250 Duro-NC 250 Duro-NCE 250 Duro-NCE 315	ROTA-S 250 ROTA-G 250 THW 250-F-R THW 265-F-R THW 315-R THWB 265 ROTA NC-WF 250 ROTA-S PLUS 250 ROTA NC-W 265 ROTA-G 315 ROTA NC-W 315 ROTA NC-WF 315
SBK 400	080966	240	120	75	69	110	12	26	54	54	320	25,2	HG-N 400 HG-F 315 KNCS-N 400 KNCS-NB 400	RMG 315 HG 400 KNCS 400	KHNC 400	F 315 UNC 400 KTNC 360 KTNC 400 KTNCV 400 FNC 400 F+315		Duro 315 Duro-NC 315 Duro-NCE 400	ROTA-S 315 THW 315-F THW 400-F-R THWB 315 ROTA-S PLUS 315 ROTA-G 400 ROTA NC-W 400

Weiche Aufsatzbacken
Kreuzversatz

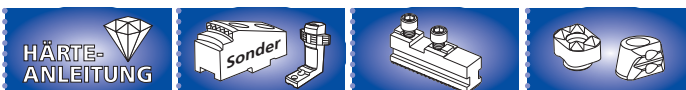

Seite 147

Seite 81
Seite 95
Seite 140

Seite 98
Seite 120

Seite 66

Weiche Segmentbacken Alu leichte Ausführung

SBK-A für Backenschnellwechsel

Kreuzversatz

Werkstoff: Aluminium (Festigkeit ca. 500 N/mm²)

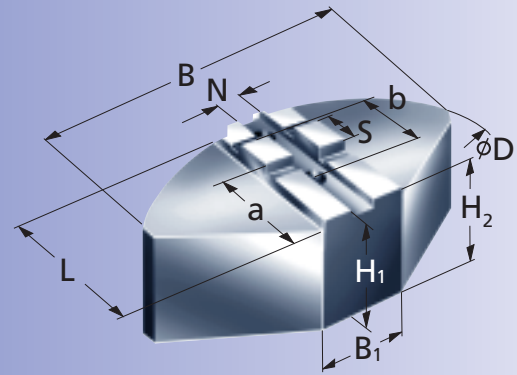

Typ	Id.-Nr.	B	B ₁	H ₁	H ₂	L	N	S	a	b	D	kg/ Satz	SMW- AUTOBLOK	SMW	Berg	Forkardt	Kitagawa	Röhms	Schunk
SBK-A 160	080967	120	40	50	46	60	8	18	23	32	160	1,6	HG-N 160 HG-F 160 KNCS-N 170	RMG 160 HG 160 KNSP 160 KNCS 160 KNCS 175	KHNC 160 KHNC 185	F 160 KTNC 160 KTNCV 160 KTNCV 175 FNC 175 F+160		Duro 160 Duro-NC 160 Duro-NC 175 Duro-NCE 160	ROTA-S 160 THW 165 ROTA-G 160 ROTA NC-W 185 ROTA-S PLUS 160
SBK-A 200	080968	140	55	60	56	75	10	20	27	40	200	3,1	HG-N 210 HG-F 210 KNCS-N 210 KNCS-N 225 KNCS-NB 210	RMG 200 HG 200 KNSP 200 KNCS 200 KNCS 210	KHNC 200	F 200 KTNC 200 KTNCV 200 FNC 200 F+200	QJ 8" (QJ 210-43)	Duro 200 Duro-NC 200 Duro-NC 225 Duro-NCE 200	ROTA-S 200 THW 210-F/R THWB 210 ROTA-G 200 ROTA NC-W 225 ROTA-S PLUS 200 ROTA NC-WF 210
SBK-A 250	080969	180	70	60	55	90	12	20	44	40	250	4,3	HG-N 260 HG-N 315 HG-F 260 KNCS-N 260 KNCS-N 315 KNCS-NB 260 KNCS-NB 315	RMG 250 HG 250 HG 315 KNCS 250 KNCS 260 KNCS 315	KHNC 250 KHNC 315	F 250 UNC 250/315 KTNC 250 KTNCV 250 KTNC 265 KTNC 280 KTNC 315 KTNCV 315 FNC 250 FNC 315 F+250	QJ 10" (QJ 254-65) QJ 12" (QJ 315-78)	Duro 250 Duro-NC 250 Duro-NCE 250 Duro-NCE 315	ROTA-S 250 ROTA-G 250 THW 250-F/R THW 265-F/R THW 315-R THWB 265 ROTA NC-WF 250 ROTA-S PLUS 250 ROTA NC-W 265 ROTA-G 315 ROTA NC-W 315 ROTA NC-WF 315
SBK-A 400	080970	240	120	75	69	110	12	26	54	54	320	9,3	HG-N 400 HG-F 315 KNCS-N 400 KNCS-NB 400	RMG 315 HG 400 KNCS 400	KHNC 400	F 315 UNC 400 KTNC 360 KTNC 400 KTNCV 400 FNC 400 F+315		Duro 315 Duro-NC 315 Duro-NCE 400	ROTA-S 315 THW 315-F THW 400-F/R THWB 315 ROTA-S PLUS 315 ROTA-G 400 ROTA NC-W 400
SBK-A 500	085193	330	150	90	83	160	18	30	95	60	440	21,4	HG-N 500 HG-N 630 HG-F 400 HG-F 500 KNCS-N 500 KNCS-N 630 KNCS-NB 500 KNCS-NB 630 KNCS-NB 800	HG 500 HG 630 KNCS 500 KNCS 630	KHNC 500	F 400/500 L UNC 500 KTNC 500/630 KTNCV 500 KTNCV 630 FNC 500 FNC 630 F+400 F+500L		Duro 400 Duro-NC 400 Duro 500 Duro-NC 500 Duro-NCE 500	ROTA-S 400 ROTA-S 500 THW 500-F/R THW 630-R THWB 400 ROTA-S PLUS 400 ROTA-S PLUS 500 ROTA-G 500

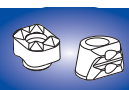
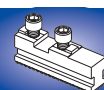

Seite 81
Seite 95
Seite 140

Seite 98
Seite 120

Seite 66

Weiche Aufsatzbacken

WBR für Zwei- und Dreibacken-Kraftspannfutter

Kreuzversatz

Werkstoff: 16MnCr5

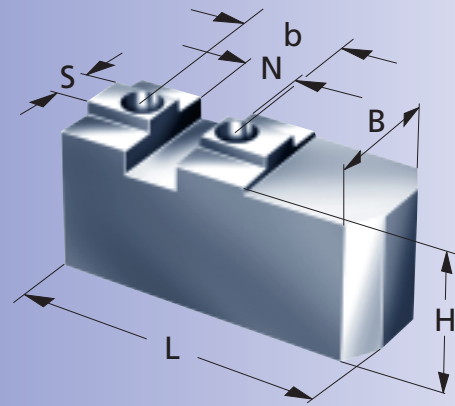

Typ	Id.-Nr.	B	H	L	S	N	b	kg/Satz	SMW-AUTOBLOK	SMW	Geiger + Haag	Röhm
WBR 1101	013843	20	25	50	8	8	15	0,7	HFKN-C 110	HFKS 110	GHN 125	KFD 110 KFD 125
WBR 1104	013844	25	30	65	8	10	22	1,0		HFKS 130		



Seite 147

Seite 81
Seite 95
Seite 140

Seite 66

Weiche Aufsatzbacken

WBK für Zwei- und Dreibacken-Kraftspannfutter

Kreuzversatz

Werkstoff: 16MnCr5/*C45

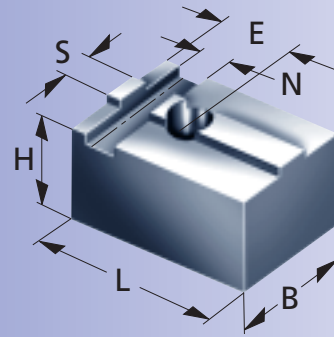

Typ	Id.-Nr.	B	H	L	S	N	E	kg/ Stück	SMW- AUTOBLOK	SMW	Berg	Forkardt	Röhm	Schunk
WBK 0801*	90040800	30	30	38	8	8	14	0,18	2 CL-C 80		MF 3/80 MFZ 2/80 MFZ 3/80 KF 2/80			ROTA 2 B 80
WBK 0851**	080983	22	30	40	8	8	-	0,16					KFD 85	
WBK 0951**	080984	22	40	44,5	8	8	-	0,25					KFD 95	
WBK 1001*	90041000	30	30	48	8	8	20	0,23	2 CL-C 100		MF 2/100 MF 3/100 MFZ 2/100 MFZ 3/100 KF 2/100 KF 3/100			ROTA 2 B 100
WBK 1201*	90041300	35	35	57	14	16	27	0,4	2 CL-C 125 US 2 CL-C 125	KZF 125 KZF-ES 125		2 BLE 125	KFA 125 2 BLN 125	ROTA 2 B 125
WBK 1602*	90041600	40	40	75	18	18	34	0,72	2 CL-C 160 US 2 CL-C 160	KZF 160 KZF-ES 160		2 BLE 160	KFA 160 2 BLE 160/PK 160 2 BLN 160	ROTA 2 B 160

**Backen angeschrägt



Seite 147

Seite 81
Seite 95
Seite 140

Seite 66

Weiche Aufsatzbacken

WA-RN

Zwei-, Drei- und Vierbackenausführung für
Planspiral-Handspannfutter und Planscheiben

Kreuzversatz

Fabrikate Amestra, Ladner, Röh, Pratt-Burned
Werkstoff: 16MnCr5

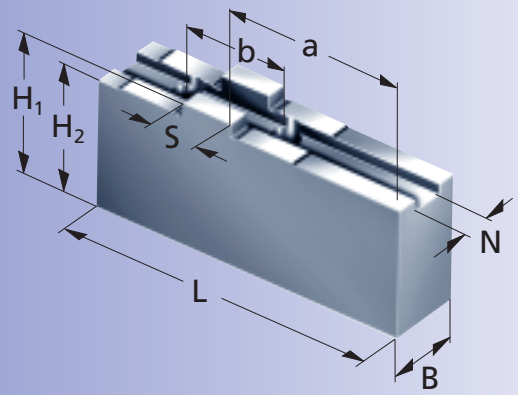

Typ	Id.-Nr.	B	H ₁	H ₂	L	N	S	a	b	DIN 912	kg/Stück	Röh
WA-RN 160	081006	30	45	42	74	7,96	12,67	32,2	38,1	M8	0,6	ZGU 140 ZGU 160 ZGF 160 ZSU 140 ZSU 160
WA-RN 200	081007	30	50	47	87	7,96	12,67	38,7	44,5	M8	0,8	ZGD 200/300 ZGU 200 ZGF 200 ZSU 200 UGU 200 USU 200
WA-RN 250	081008	35	60	57	103	12,72	19,02	43,5	54	M12	1,35	ZGD 250/270 ZGU 250 ZSU 260 ZGF 250 UGU 260 USU 260
WA-RN 315	081009	40	60	57	120	12,72	19,02	53	63,5	M12	1,9	ZGD 315 ZGU 315 ZSU 315 ZGF 315 UGU 310/350 USU 310/350
WA-RN 350/400	081010	50	80	73,7	137	12,72	19,02	62	76,2	M16	3,3	ZGD 400 ZGU 350 ZGU 400 ZSU 350 ZSU 400 ZGF 350 ZGF 400 UGU 400/450 USU 400/450



Seite 147

Seite 81
Seite 95
Seite 140

Seite 66

Weiche Aufsatzbacken

WAKA

Zwei-, Drei- und Vierbackenausführung

American Standard

Werkstoff: C45

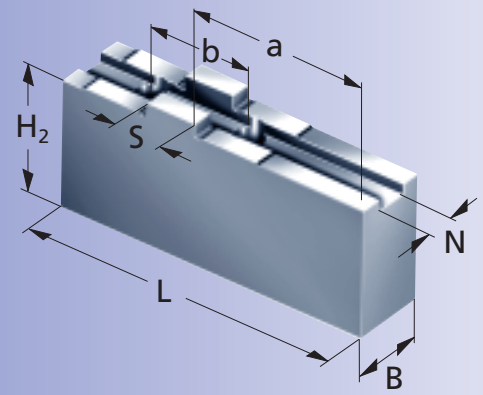

Typ	Id.-Nr.	B	H ₂	L	N	S	a	b	DIN 912	kg/Stück	SMW-AUTOBLOK
WAKA 165	12041660	30	35	80	7,94	12,68	43,6	38,1	M10	0,58	AN-C 165 HB-C 165 PC-C 165 PBI-C 165
WAKA 210	12042060	40	40	100	7,94	12,68	58,66	44,4	M12	0,92	AN-C 210 HB-C 210 PB-C 210 PBI-C 210
WAKA 250	12042560	50	50	120	12,7	19,03	68,5	54	M16	1,25	AN-C 250 HB-C 250 PB-C 250 PBI-C 250
WAKA 315	12043060	50	50	140	12,7	19,03	80,5	63,5	M16	2,15	AN-C 315 HB-C 315 PB-C 315 PBI-C 315
WAKA 400	12044050	60	60	165	12,7	19,03	95,5	76,2	M20	3,6	AN-C 400
WAKA 500	12045050	75	75	165	12,7	19,03	95,5	76,2	M20	5,5	IN-C 500 IN-C 630 IN-C 800



Seite 147

Seite 81
Seite 95
Seite 140

Seite 66