

# Ultra Live Center RN

Type RN with morse taper

## Clamping tools for clamping on machine tools

NEIDLEIN ultra live centers are designed for employment in turning, grinding and other production machines.

Owing to the application of bearing and the stable construction high axial and radial load can be absorbed accurately. Therefore our live centers are outstanding for any application, especially for tooling with face drivers.

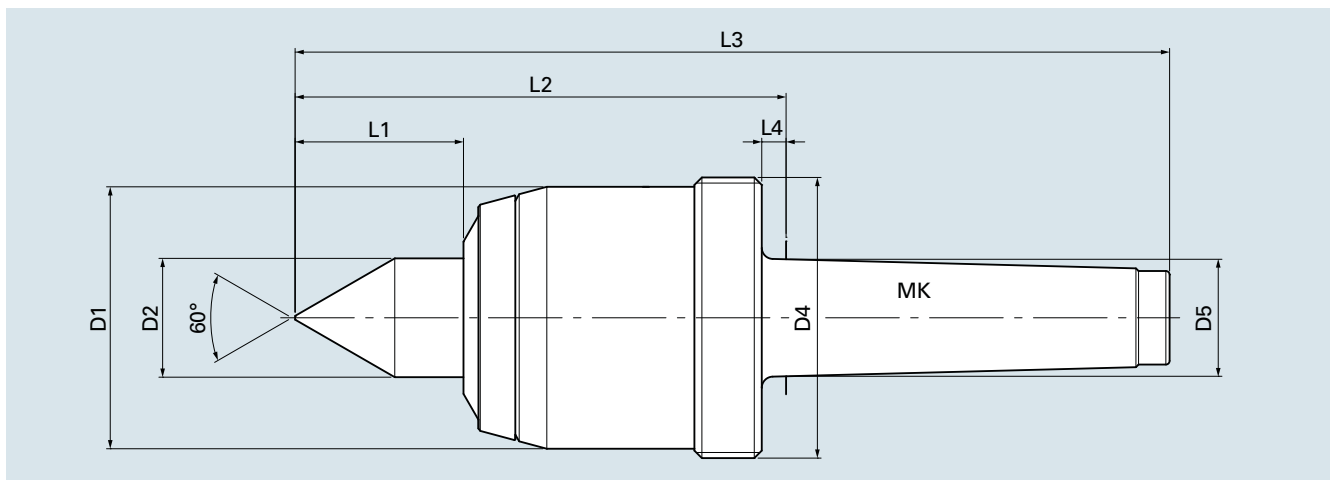

cat. no. turning	cat. no. grinding	type	MK	D1	D2	D4	D5	L1	L2	L3	L4	rpm max. [1/min]	weight of work piece max. [kg]	axial load max. [daN]
81201	8120102	RN3 MK3	3	55	22	M58 x 1.5	23.83	26	102	183	5	8000	440	500
81202	8120202	RN3 MK4	4	55	22	M58 x 1.5	31.27	26	103.5	206	6.5	8000	440	500
81203	8120302	RN3 MK5	5	55	22	M58 x 1.5	44.40	26	103.5	233	6.5	8000	440	500
81204	8120402	RN4 MK4	4	70	32	M75 x 1.5	31.27	45	131.2	233.7	6.5	7000	700	800
81205	8120502	RN4 MK5	5	70	32	M75 x 1.5	44.40	45	131.2	260.7	6.5	7000	700	800
81206	8120602	RN5 MK5	5	92	45	M95 x 2	44.40	60	156.2	285.7	6.5	5000	1400	1500
81207	8120702	RN5 MK6	6	92	45	M95 x 2	63.35	60	157.7	339.7	8	5000	1400	1500
81208	8120802	RN6 MK6	6	107	55	M110 x 2	63.35	60	169.7	351.7	8	3000	2000	2000

## NEIDLEIN revolving ultra live centers type RN ensure:

- Application of live centers in case of high thrust and loading.
- high true running accuracy  
max. 0.005 turning type  
max. 0.003 grinding type
- enhanced true running accuracy HQ  
All our specified live centers can be obtained with enhanced true running accuracy of max. 0.002.  
cat. no. = 812XX1  
e.g. RN4 MK4 type HQ cat. no. 812041
- Maintenance-free, due to gasket system and lifetime lubrication of bearings. Gasket system comprising variable seal and steel protection cover.
- Excellent demounting by means of extracting nut and extracting disk, which ensures safe and easy removal of the live center from the tailstock spindle sleeve.

Extracting nuts and extracting disks see page 19 for accessories.



**Type turning**

- with contact-free labyrinth seal

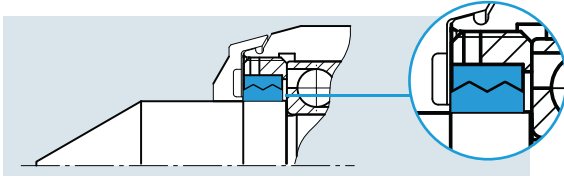

- true running accuracy max. 0.005 guaranteed

**Type grinding**

- with contact shaft seal

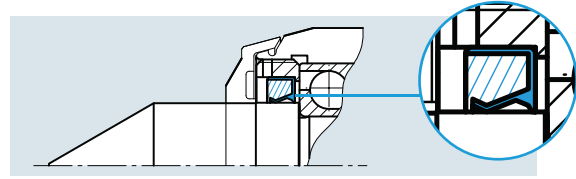

- true running accuracy max. 0.003 guaranteed

**Type RN with carbide tip for hardened work pieces**

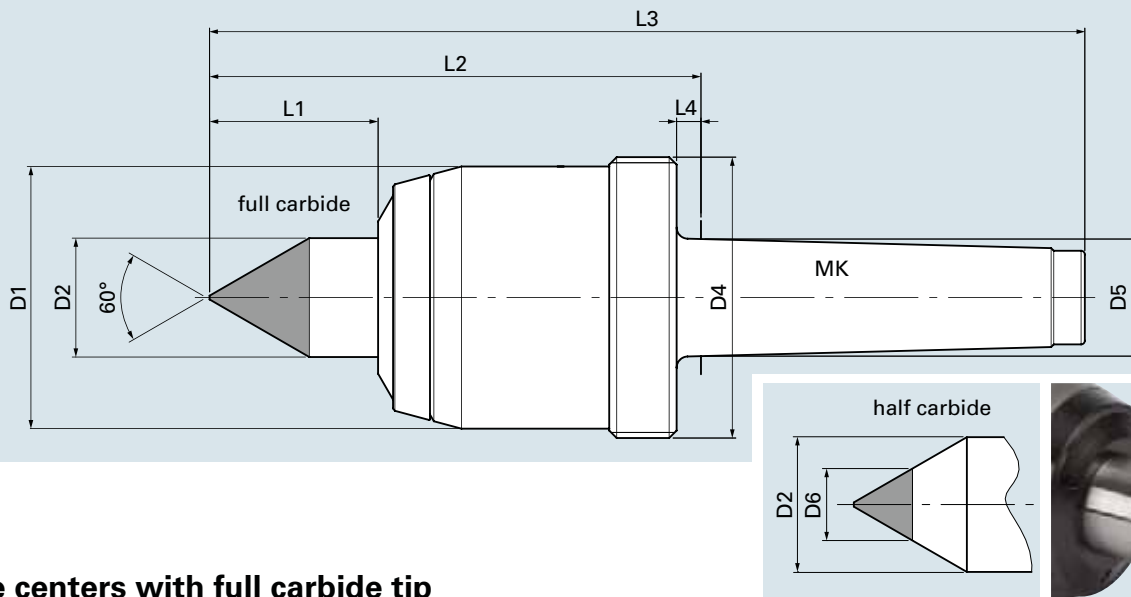

**Live centers with full carbide tip**

cat. no. turning	cat. no. grinding	type full carbide	MK	D1	D2	D4	D5	L1	L2	L3	L4	rpm max. [1/min]	weight of work piece max. [kg]	axial load max. [daN]
8120104	8120106	RN3 MK3	3	55	22	M58 x 1.5	23.83	26	102	183	5	8000	440	500
8120204	8120206	RN3 MK4	4	55	22	M58 x 1.5	31.27	26	103.5	206	6.5	8000	440	500
8120304	8120306	RN3 MK5	5	55	22	M58 x 1.5	44.40	26	103.5	233	6.5	8000	440	500
8120404	8120406	RN4 MK4	4	70	32	M75 x 1.5	31.27	45	131.2	233.7	6.5	7000	700	800
8120504	8120506	RN4 MK5	5	70	32	M75 x 1.5	44.40	45	131.2	260.7	6.5	7000	700	800
8120604	8120606	RN5 MK5	5	92	45	M95 x 2	44.40	60	156.2	285.7	6.5	5000	1400	1500
8120704	8120706	RN5 MK6	6	92	45	M95 x 2	63.35	60	157.7	339.7	8	5000	1400	1500
8120804	8120806	RN6 MK6	6	107	55	M110 x 2	63.35	60	169.7	351.7	8	3000	2000	2000

**Live centers with half-carbide tip**

cat. no. turning	cat. no. grinding	type half carbide	MK	D1	D2	D4	D5	D6	L1	L2	L3	L4	rpm max. [1/min]	weight of work piece max. [kg]	axial load max. [daN]
8120103	8120105	RN3 MK3	3	55	22	M58 x 1.5	23.83	11	26	102	183	5	8000	440	500
8120203	8120205	RN3 MK4	4	55	22	M58 x 1.5	31.27	11	26	103.5	206	6.5	8000	440	500
8120303	8120305	RN3 MK5	5	55	22	M58 x 1.5	44.40	11	26	103.5	233	6.5	8000	440	500
8120403	8120405	RN4 MK4	4	70	32	M75 x 1.5	31.27	14	45	131.2	233.7	6.5	7000	700	800
8120503	8120505	RN4 MK5	5	70	32	M75 x 1.5	44.40	14	45	131.2	260.7	6.5	7000	700	800
8120603	8120605	RN5 MK5	5	92	45	M95 x 2	44.40	22	60	156.2	285.7	6.5	5000	1400	1500
8120703	8120705	RN5 MK6	6	92	45	M95 x 2	63.35	22	60	157.7	339.7	8	5000	1400	1500
8120803	8120805	RN6 MK6	6	107	55	M110 x 2	63.35	28	60	169.7	351.7	8	3000	2000	2000

Extracting nuts and extracting disks see page 19 for accessories.