

PIATF-4GR

Piattaforme M.P.T. a 4 griffe indipendenti - Attacco a flangia M.P.T. 4-jaw independent chucks - Plain back mounting

• Corpo in acciaio fuso
Molten steel body

• Griffe in 2 pezzi
2-piece jaws

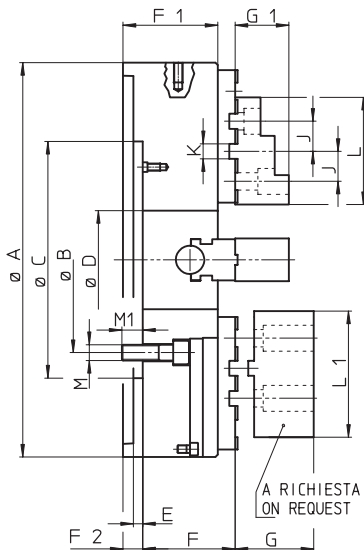
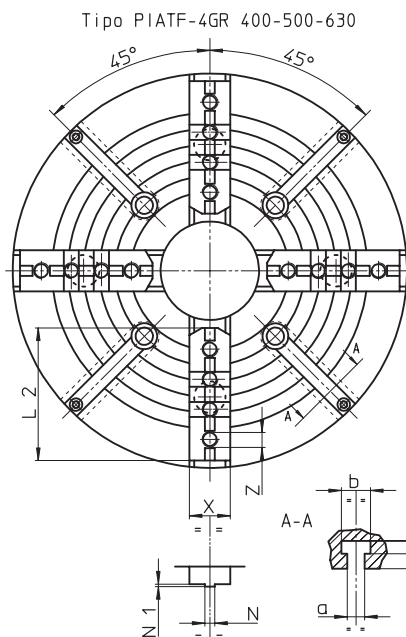
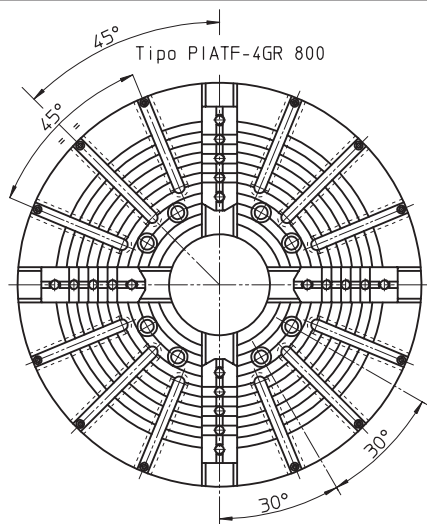

Soggetto a cambiamenti tecnici / Subject to technical changes

MPT tipo PIATF-4GR		400*	500	630	800
Attacco/Mounting	DIM	FL220	FL300	FL300	FL380
	A	400	500	630	800
	B	171,4	235	235	330,2
	C (H4)	220	300	300	380
	D	100	125	160	200
	E	10	12	12	12
	F	...	117,1	137,1	147,1
	F1	105	120	140	160
	F2	23	25	25	25
	G	58,2	75,7	75,7	75,7
	G1	58,2	68,2	75,7	81,7
	J ±0,1	38,1	38,1	38,1	38,1
	K +0,01	19,04	19,04	19,04	19,04
	L	129	136	136	136
	L1	140	160	160	160
	L2	129	168	206	206
	M	4xM16	4xM20	4xM20	8xM24
M1		26,5	31,5	30,5	
N -0,03	12,7	12,7	12,7	12,7	
N1	3,2	3,2	3,2	3,2	
Chiave/Key	QUADRO		17	19	19
	X (h6)	40	52	52	70
	Z	M16	M20	M20	M20
	a (H10)	18	22	22	22
	b +3	30	37	37	37
	c	30	35	35	35
	d +2	12	16	16	16
Velocità max./Max speed **	giri/min	1100	700	550	450
Coppia/Torque M max	N.m	120	140	160	300
Massa con gr./Weight (w. jaws)	Kg		142	209	356
Mom. d'inerzia/Mom. of inertia	Kgm ²		4,4	10,4	28,5

Dotazione standard:
1 Set-4 false griffe
1 Set-4 griffe reversibili

Standard equipment:
1 Set of 4 master jaws
1 Set of 4 reversible jaws

* Disponibile su richiesta
Available on request

** Valide con pezzo bloccato perfettamente bilanciato
With clamped workpiece perfectly balanced

Codice d'ordine/Ordering example	33037440	33037450	33037463	33037480
---	----------	----------	----------	----------

A RICHIESTA ON REQUEST	 Set-4 bloc. teneri/Soft jaws	03604040	03606340	03606340	03606340
-------------------------------	--	----------	----------	----------	----------

PIATF-4GR

Flange ISO-A per piattaforme M.P.T. a 4 griffe indipendenti
 ISO-A adapters for MPT 4 jaw independent chucks

• Ricambi
 Spare parts

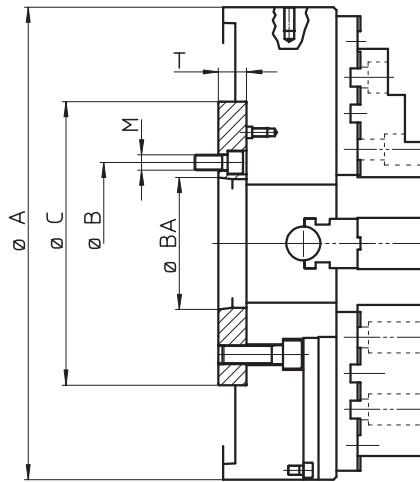

Tipo 2
 montaggio ISO-A di riduzione
 reduction ISO-A mounting

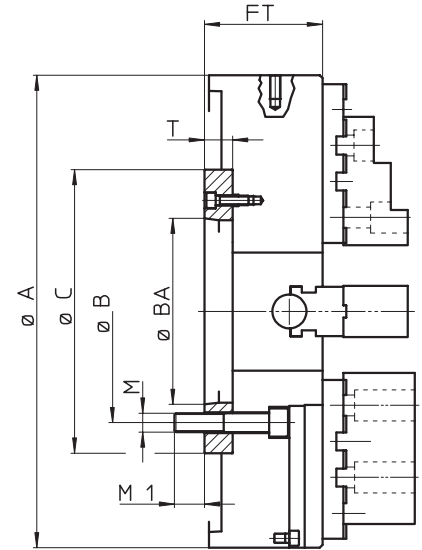

Tipo 1
 montaggio ISO-A diretto
 direct ISO-A mounting

Soggetto a cambiamenti tecnici / Subject to technical changes

Flange montaggio ISO-A tipo 1 diretto / Direct ISO-A mounting - type 1

Flangia cod.	Naso macch.	A	B	BA	C	M	M1	T	FT
24182510	A8	400	171,4	139,719	220	N°4-M16x80	18,5	27	109
24113110	A11	500	235	196,869	300	N°4-M20x100	31,5	30	125
		630							145
24127100	A15	800	330,2	285,775	380	N°8-M24x180	37,5	33	168

Flange montaggio ISO-A tipo 2 di riduzione / Reduction ISO-A mounting - type 2

Flangia cod.	Naso macch.	A	B	BA	C	M	M1
24152500	A5	400	104,8	82,563	220	M10	24
24162530	A6		133,4	106,375			
24163100	A6	500-630	171,4	139,719	300	M12	30
24183100	A8						
24185000	A8	800	235	196,869	380	M16	40
24115000	A11						

MPT tipo PIATF-4GR / MPT 4 jaw independent chuck

	400*	500	630	800
Set-4 false gr./Mster jaws	03574070	03575070	03576370	03578070
Set-4 grif.rev./Rev. jaws	03634070	03635070	03636370	03638070
Set-4 bloc.teneri/soft jaws	03604040	03606340	03606340	03606340
Vite serraggio/Screw	03704070	03705070	03706370	03708070
Forc. di ritegno/Check fork	03674070	03675070	03676370	03678070
Chiave di sic./Safety key		02714000	02716300	
Grasso/Grease	10731131			

RICAMBI/SPARE PARTS