

Soggetto a cambiamenti tecnici
Subject to technical changes

EM-C 1

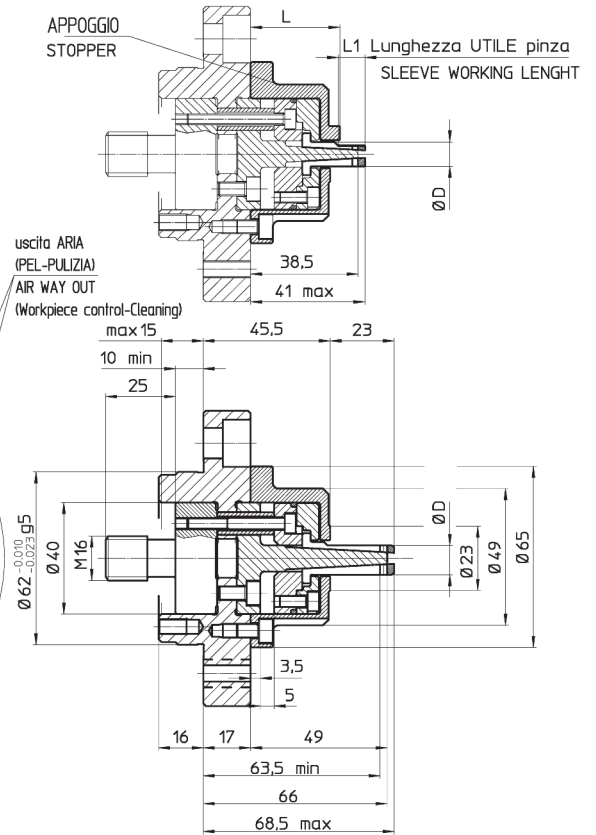

EM-C 2-3

EM-C 1				EM-C 2			EM-C 3			
Cod. Mandrino Chuck Code	D	L	L1	Cod. Pinza Sleeve Code	Cod. Mandrino Chuck Code	D	Cod. Pinza Sleeve Code	Cod. Mandrino Chuck Code	D	Cod. Pinza Sleeve Code
EM-C1.1	5.8			68270058	68100230	9.3	68270093	68100330	12.3	68270123
68100130	6.3	32	9.5	68270063		9.8	68270098		12.8	68270128
	6.8			68270068		10.3	68270103		13.3	68270133
	7.3			68270073		10.8	68270108		13.8	68270138
EM-C1.2	7.8	28.5	13	68270078		11.3	68270113		14.3	68270143
68110130	8.3			68270083	11.8	68270118	14.8	68270148		
	8.8			68270088			15.3	68270153		
							15.8	68270158		

Corsa assiale - Axial stroke	mm	5	5	5
Forza max. assiale Max axial force	kN	1	2	3
Espansione pinza sul \varnothing Sleeve expansion on \varnothing	mm	0.5	0.5	0.5
Campo di bloccaggio \varnothing Clamping range \varnothing	mm	5.8 - 9.3	9.3 - 12.3	12.3 - 16.3
Cilindri consigliati Recommended cylinders	CSN SIN-S	100 70	100 70	100 70

Per flange di attacco vedi pagina 96.
Per applicazioni speciali contattare il nostro ufficio tecnico.

For adapters see page 96.
For customized applications please call our technical office.

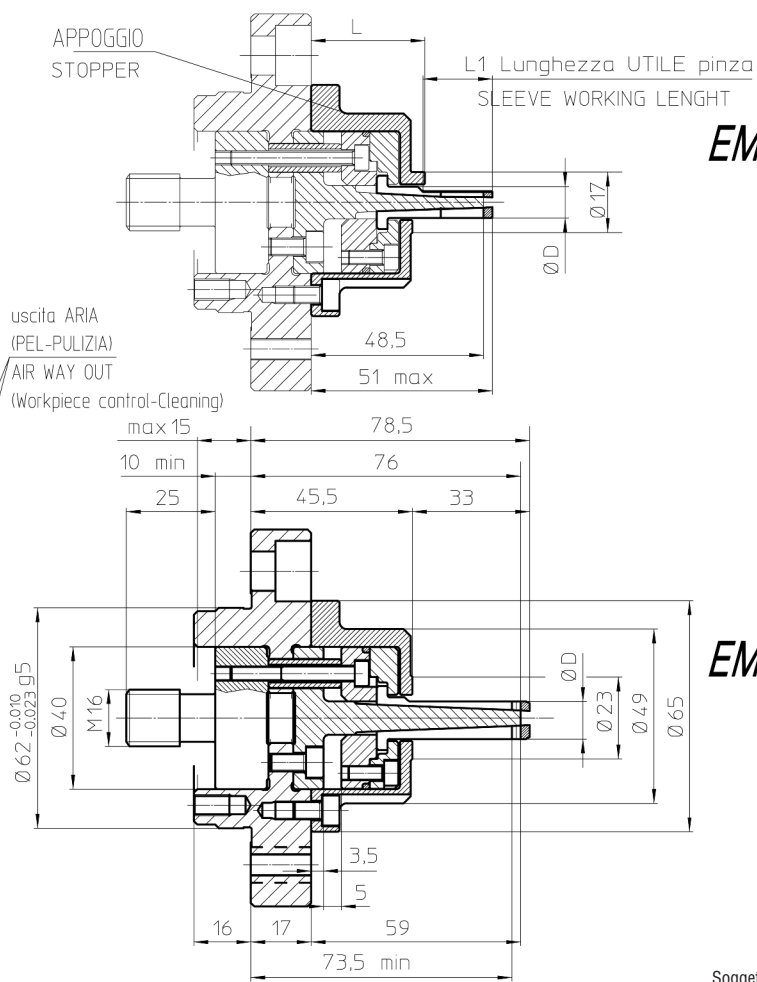
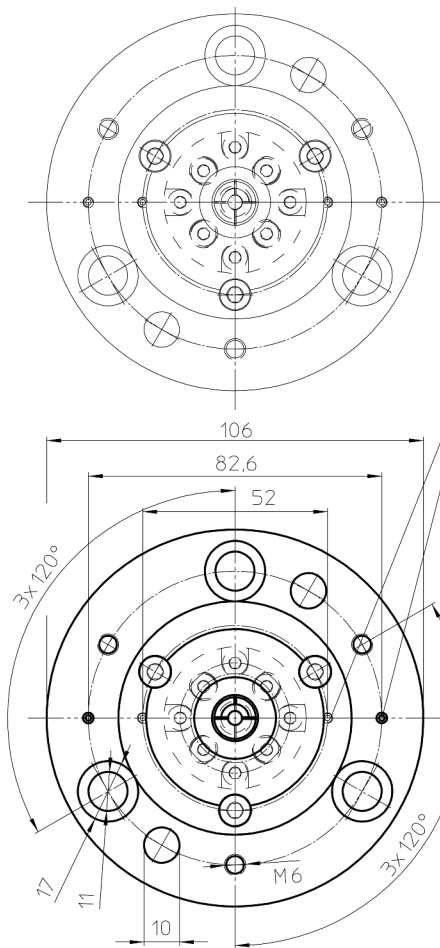

EM-CL 1

EM-CL2-3

Soggetto a cambiamenti tecnici
Subject to technical changes

EM-CL 1					EM-CL 2			EM-CL 3		
Cod. Mandrino Chuck Code	D	L	L1	Cod. Pinza Sleeve Code	Cod. Mandrino Chuck Code	D	Cod. Pinza Sleeve Code	Cod. Mandrino Chuck Code	D	Cod. Pinza Sleeve Code
EM-C1.1	5.8			68260058	68100240	9.3	68260093	68100340	12.3	68260123
68100140	6.1			68260061		9.6	68260096		12.6	68260126
	6.4	32	19.5	68260064		9.9	68260099		12.9	68260129
	6.7			68260067		10.2	68260102		13.2	68260132
	7.0			68260070		10.5	68260105		13.5	68260135
	7.3			68260073		10.8	68260108		13.8	68260138
EM-C1.2	7.6	28.5	23	68260076		11.1	68260111		14.1	68260141
68110140	7.9			68260079		11.4	68260114		14.4	68260144
	8.2			68260082		11.7	68260117		14.7	68260147
	8.5			68260085		12.0	68260120		15.0	68260150
	8.8			68260088			15.3	68260153		
	9.1			68260091			15.6	68260156		
							15.9	68260159		
							16.2	68260162		

Corsa assiale - Axial stroke	mm	5	5	5
Forza max. assiale Max axial force	kN	1	2	3
Espansione pinza sul Ø Sleeve expansion on Ø	mm	0.3	0.3	0.3
Campo di bloccaggio Ø Clamping range Ø	mm	5.8 - 9.4	9.3 - 12.3	12.3 - 16.5
Cilindri consigliati Recommended cylinders	CSN SIN-S	100 70	100 70	100 70

Per flange di attacco vedi
pagina 96.
Per applicazioni speciali
contattare il nostro ufficio
tecnico.

*For adapters see page 96.
For customized applications
please call our technical
office.*