

# EM-A/ EM-AL

Expanding mandrel  
Manual or power operated

## Expanding mandrels $\varnothing$ 14.7 - 129.7 mm

- size 1 - 11
- large expansibility
- EM-AL: body lengthened

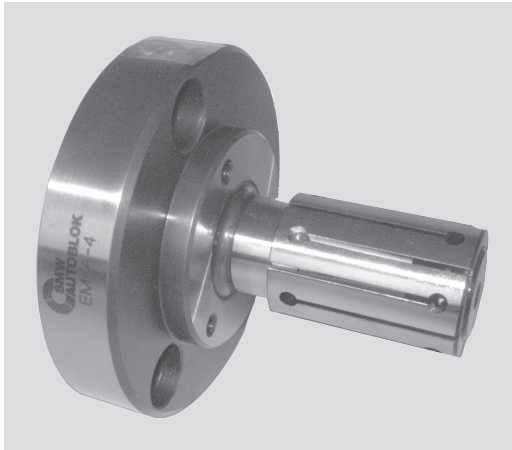

### Application/customer benefits

- For turning, milling, grinding and gear cutting operations
- High accuracy and torque transmission because of fixed arbor
- Axial pull down by axial movement of the clamping sleeve during actuation
- Quick set-up

### Technical features

- Large expansibility 1-2 mm depending on size
- Hand or power operated
- Flange mounting
- Very rigid design
- Tapped holes at the front face to mount axial stops
- Clamping sleeves are also available in siliconized version
- EM-AL: clamping mandrel with extra long body

### Standard equipment

Basic mandrel with draw bolt for power operation  
Mounting bolts

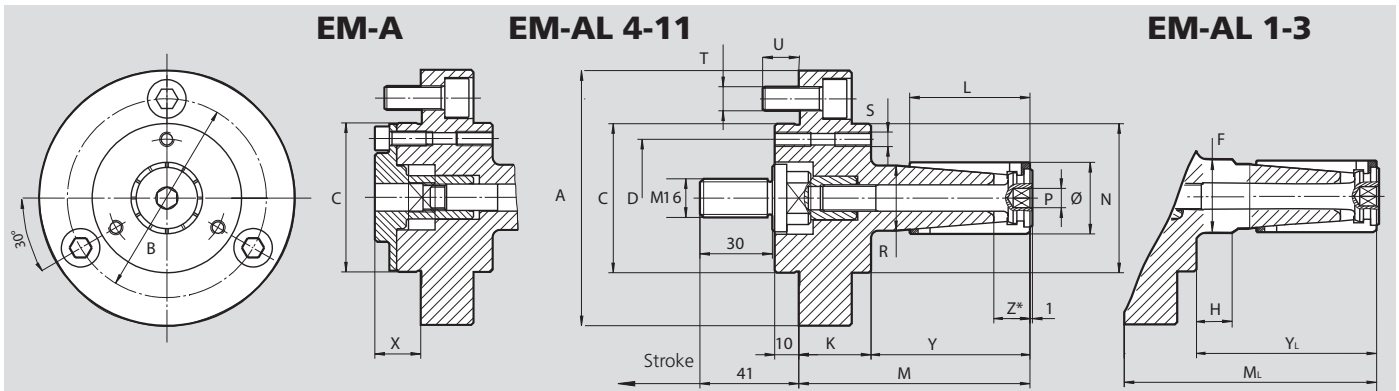

Subject to technical changes.  
For more detailed information please ask for customer drawing.

SMW-AUTOBLOK Type	EM-A-1 EM-AL-1	EM-A-2 EM-AL-2	EM-A-3 EM-AL-3	EM-A-4 EM-AL-4	EM-A-5 EM-AL-5	EM-A-6 EM-AL-6	EM-A-7 EM-AL-7	EM-A-8 EM-AL-8	EM-A-9 EM-AL-9	EM-A-10 EM-AL-10	EM-A-11 EM-AL-11
EM-A Id. No. (power operated)	68100110	68100210	68100310	68100410	68100510	68100610	68100710	68100810	68100910	68101010	68101110
EM-AL Id. No. (power operated)	68100111	68100211	68100311	68100411	68100511	68100611	68100711	68100811	68100911	68101011	68101111
A	106	106	106	106	106	106	130	130	130	130	130
B	82.6	82.6	82.6	82.6	82.6	82.6	104.8	104.8	104.8	104.8	104.8
C	g5 62	62	62	62	62	62	86	86	86	86	86
D	49	49	49	49	49	49	73	73	73	100	100
F	22	23	26	-	-	-	-	-	-	-	-
H	25	30	35	-	-	-	-	-	-	-	-
K	30	30	30	30	30	30	30	30	30	30	30
L	35	40	46	50	60	60	80	90	100	122	140
M	81	86	92	96	106	106	132	142	152	174	195
ML	106	116	127	136	146	146	182	188	222	248	275
N	62	62	62	62	62	62	86	86	86	-	-
Ø	mm 14.7-19.7	19.7-24.7	24.7-29.7	29.7-34.7	34.7-39.7	39.7-44.7	44.7-54.7	54.7-64.7	64.7-81.7	81.7-101.7	101.7-131.7
P	SW 4	4	6	8	8	8	8	10	10	10	10
R	h6 14	19	23	27	31.5	36	42	50	60	73	86
S	(3x120°) M6	M6	M6	M6	M6	M6	M6	M6	M6	M6	M6
T	(3x120°) M10	M10	M10	M10	M10	M10	M10	M10	M10	M10	M10
U	15	15	15	15	15	15	15	15	15	17	17
X	19	19	19	19	19	19	13	13	13	21	21
Y	51	56	62	66	76	76	102	112	122	144	165
YL	76	86	97	106	116	116	152	158	192	218	245
Z*	12.5	14.5	14.5	15	15.5	16	24	26	26.5	27.5	32
Manual kit EM-A	68110110	68110210	68110310	68110410	68110510	68110610	68110710	68110810	68110810	68111010	68111110
Manual kit EM-AL	68110111	68110211	68110311	68110411	68110511	68110611	68110711	68110811	68110811	68111011	68111111
Draw bolt power op. EM-A	68050110	68050210	68050310	68050410	68050510	68050610	68050710	68050710	68050710	68051010	68051110
Draw bolt power op. EM-AL	68050111	68050211	68050311	68050411	68050511	68050611	68050711	68050811	68050911	68051011	68051111

\* Clamping on area Z only is not allowed.

### Technical data

Stroke	mm	6	6	6	6	6	12	12	12	12	12
Max. actuating force	kN	5	7	12	12	15	20	20	20	25	30
Max. transm. torque	Nm	15	35	75	100	120	150	200	250	275	500
Actuating cylinder (rec.)		<b>SIN-S 70</b>	<b>SIN-S 70</b>	<b>SIN-S 85</b>	<b>SIN-S 85</b>	<b>SIN-S 85</b>	<b>SIN-S 100</b>	<b>SIN-S 100</b>	<b>SIN-S100</b>	<b>SIN-S-100</b>	<b>SIN-S-100</b>

All dimensions in unclamped position



SMW-AUTOBLOK  
256

SMW-AUTOBLOK  
259

# Expanding mandrels Ø 14.7 - 129.7 mm

# EM-A/ EM-AL

- size 1 - 11
- large expansibility
- EM-AL: body lengthened

Expanding mandrel  
Manual or power operated

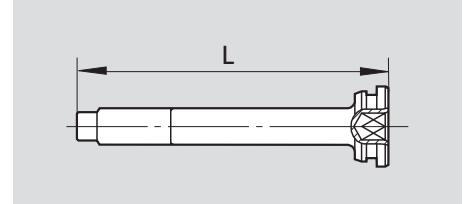
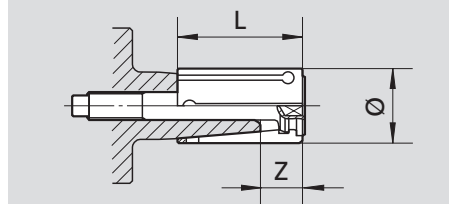
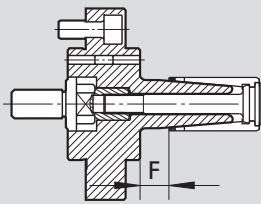

## Basic mandrel

Type	Id. No.	F
EM-A-1	68100110	16
EM-AL-1	68100111	41
EM-A-2	68100210	16
EM-AL-2	68100211	46
EM-A-3	68100310	16
EM-AL-3	68100311	51
EM-A-4	68100410	16
EM-AL-4	68100411	56
EM-A-5	68100510	16
EM-AL-5	68100511	56
EM-A-6	68100610	16
EM-AL-6	68100611	56
EM-A-7	68100710	22
EM-AL-7	68100711	72
EM-A-8	68100810	22
EM-AL-8	68100811	68
EM-A-9	68100910	22
EM-AL-9	68100911	92
EM-A-10	68101010	22
EM-AL-10	68101011	96
EM-A-11	68101110	25
EM-AL-11	68101111	105

## Clamping sleeve cpl. with actuating screw

Id. No.	Ø	L	Expansibility	Z
68300147	14.7	35	1	12.5
68300157	15.7	35	1	12.5
68300167	16.7	35	1	12.5
68300177	17.7	35	1	12.5
68300187	18.7	35	1	12.5
68300197	19.7	40	1	14.5
68300207	20.7	40	1	14.5
68300217	21.7	40	1	14.5
68300227	22.7	40	1	14.5
68300237	23.7	40	1	14.5
68300247	24.7	46	1	14.5
68300257	25.7	46	1	14.5
68300267	26.7	46	1	14.5
68300277	27.7	46	1	14.5
68300287	28.7	46	1	14.5
68300297	29.7	50	1	15
68300307	30.7	50	1	15
68300317	31.7	50	1	15
68300327	32.7	50	1	15
68300337	33.7	50	1	15
68300347	34.7	60	1	15.5
68300357	35.7	60	1	15.5
68300367	36.7	60	1	15.5
68300377	37.7	60	1	15.5
68300387	38.7	60	1	15.5
68300397	39.7	60	1	16
68300407	40.7	60	1	16
68300417	41.7	60	1	16
68300427	42.7	60	1	16
68300437	43.7	60	1	16
68300447	44.7	80	2	24
68300467	46.7	80	2	24
68300487	48.7	80	2	24
68300497	49.7	80	2	24
68300507	50.7	80	2	24
68300527	52.7	80	2	24
68300547	54.7	90	2	26
68300567	56.7	90	2	26
68300587	58.7	90	2	26
68300597	59.7	90	2	26
68300607	60.7	90	2	26
68300627	62.7	90	2	26
68300647	64.7	100	2	26.5
68300667	66.7	100	2	26.5
68300687	68.7	100	2	26.5
68300697	69.7	100	2	26.5
68300707	70.7	100	2	26.5
68300727	72.7	100	2	26.5
68300747	74.7	100	2	26.5
68300767	76.7	100	2	26.5
68300787	78.7	100	2	26.5
68300807	80.7	100	2	26.5
68300817	81.7	122	2	27.5
68300837	83.7	122	2	27.5
68300857	85.7	122	2	27.5
68300877	87.7	122	2	27.5
68300897	89.7	122	2	27.5
68300917	91.7	122	2	27.5
68300937	93.7	122	2	27.5
68300957	95.7	122	2	27.5
68300977	97.7	122	2	27.5
68300997	99.7	122	2	27.5
68301017	101.7	140	2	32
68301037	103.7	140	2	32
68301057	105.7	140	2	32
68301077	107.7	140	2	32
68301097	109.7	140	2	32
68301117	111.7	140	2	32
68301137	113.7	140	2	32
68301157	115.7	140	2	32
68301177	117.7	140	2	32
68301197	119.7	140	2	32
68301217	121.7	140	2	32
68301237	123.7	140	2	32
68301257	125.7	140	2	32
68301277	127.7	140	2	32
68301297	129.7	140	2	32

## Actuating screw

Id. No.	L
68030110	76.5
68030210	81
68030310	87.5
68030410	93
68030510	103
68030610	103
68030710	117
68030810	127
68030910	137
68031010	165
68031110	183