

TSBF-C

Self centering
Floating jaws

TSBR-C

Self centering
Rigid jaws

High precision pull-down chucks Ø 220 - 330 mm

- active pull-down
- tongue & groove
- LARGE THROUGH HOLE
- 3 jaws



proofline® series
fully sealed – low maintenance

Application/customer benefits

- Clamping of workpieces with highest demand for **parallelism**
- **Highest productivity** with long maintenance intervals
- Constant grip force and long lifetime ensure **constant quality of workpieces**
- Through hole to insert long workpieces or for special clamping applications

TSBF-C: Floating base jaws to clamp raw and easy deformed workpieces (6-point-contact)
TSBR-C: Rigid base jaws for precise clamping on pre machined diameters

Technical features

- active pull-down
- centrifugal force compensation
- tongue & groove base jaws
- **proofline® chucks** = fully sealed – low maintenance
- permanent grease lubrication
- large through hole

Standard equipment

3 jaw chuck
mounting bolts

Ordering example

TSBF-C 220/A6
or TSBR-C 330/Z300

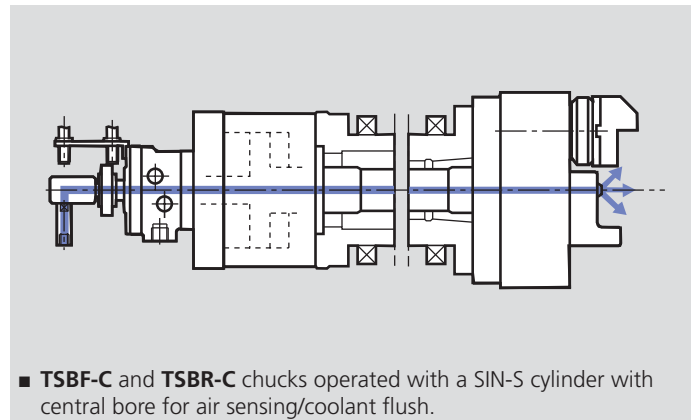
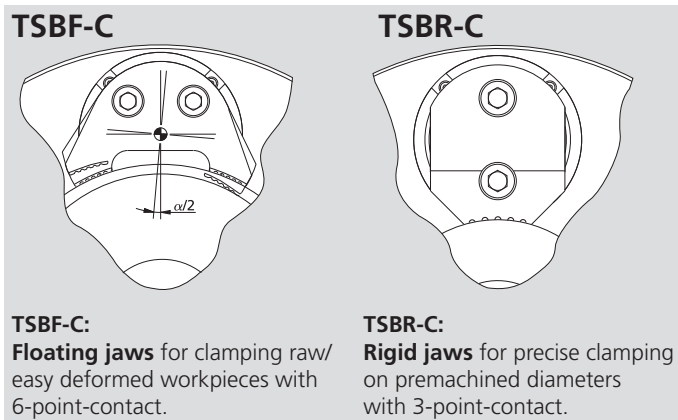
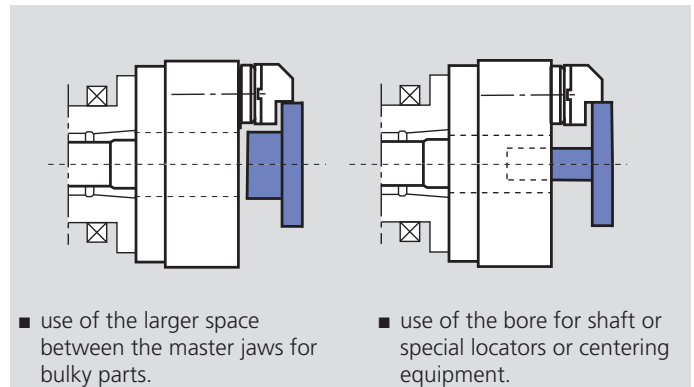
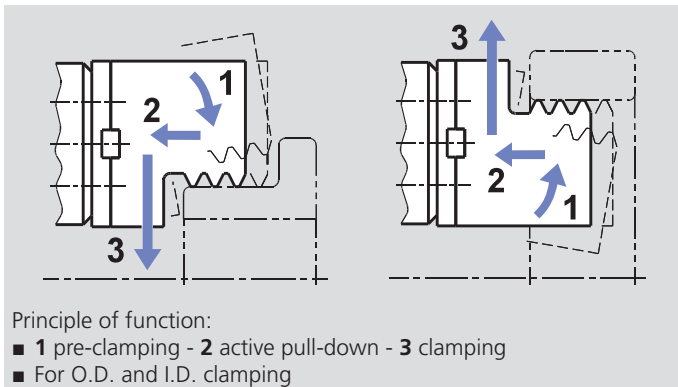

Technical data

SMW-AUTOBLOK Type		TSBF-C 220 TSBR-C 220	TSBF-C 260 TSBR-C 260	TSBF-C 330 TSBR-C 330
Angular jaw stroke U°	deg.	5.2°	5.2°	5°
Radial jaw stroke at distance h	mm	5.3	6.3	7
Pull down movement (standard)	mm	0.1	0.1	0.1
Axial piston stroke	mm	21	25	25
Max. draw pull**	kN	18	25	40
Max. gripping force at distance h**	kN	44	60	96
Max. speed*	r.p.m.	4250	3750	3000
Weight (without top jaws)	kg	25	40	67
Moment of inertia	kg·m ²	0.165	0.32	0.75
Recommended actuating cylinders	Type	SIN-S 85	SIN-S 100	SIN-S 125

* The above maximum speed is allowed with standard weight/height top jaws and applying the full draw pull only. For more informations please contact SMW-AUTOBLOK.

**For internal clamping reduce the draw pull by 30 %.



High precision pull-down chucks \varnothing 220 - 330 mm

- active pull-down
- tongue & groove
- LARGE THROUGH HOLE
- 3 jaws

TSBF-C

Self centering
Floating jaws

TSBR-C

Self centering
Rigid jaws

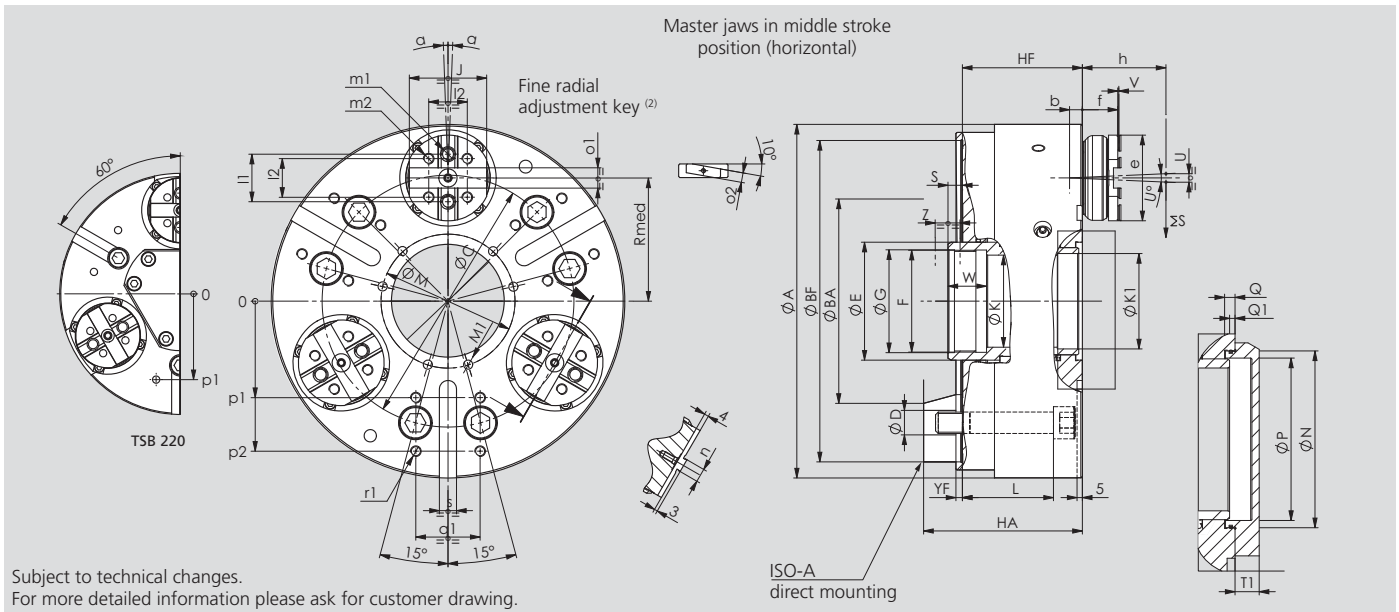

SMW-AUTOBLOK Type			TSBF-C 220 TSBR-C 220		TSBF-C 260 TSBR-C 260		TSBF-C 330 TSBR-C 330	
Mounting			Z170	A6	Z220	A8	Z300	A11
	A	mm		225		265		330
	BF/BA H6	mm	170		220		300	196.869
	C	mm		133.4		171.4		235
	D	mm		13.5		17		21
	E	mm		75		85		110
	F	mm		M65 x 2		M75 x 2		M95 x 2
	G H8	mm		66		76		96
	HF/HA	mm	86		100		112	133
Through-hole	K	mm		55		62		86
	K1	mm		-		65		89
	L	mm		66		80		85
	M	mm		88		100		125
Thread/depth	M1	mm		M8/20		M8/20		M10/20
	N H8	mm		74		85		110
	P	mm		65		75		100
	Q	mm		6.5		6.5		6.5
At middle stroke	Q1	mm		2		1		3
At middle stroke	Rmed	mm		78		90		115
At middle stroke	S	mm		15		13		14
	T1	mm		13		16		15
Radial stroke	U°	deg.		5.2°		5.2°		5°
Radial stroke ⁽¹⁾	U	mm		5.3		6.3		7
Pull-down s/d (option)	V	mm		0.1 (0.6)		0.1 (0.6)		0.1 (0.6)
	W	mm		30		34		36
Axial wedge stroke	Z	mm		21		25		25
Only TSBF-C max.	α	deg.		±2°		±2°		±1.5°
	b	mm		9		10		12
	e	mm		60		75		80
Reference height	f	mm		27		33		33
	h	mm		50		60		70
	j	mm		55		65		72
	l1	mm		32		38		44.4
	l2	mm		24		32		36
Thread/depth	m1	mm		M10/16		M12/18		M12/18
Thread/depth	m2	mm		M8/14		M10/14		M10/14
	n h8	mm		7.94		7.94		12.7
	o1 H7	mm		12.68		12.68		19.03
	o2 h7	mm		9		9		12
	p1	mm		80		102		90
	p2	mm		-		-		140
	q1	mm		45		60		60
Thread/depth	r1	mm		M8/15		M10/20		M10/20
	s	mm		16		16		16
	yF	mm		5		5		5

⁽¹⁾ Calculated at **h** distance from the chuck's face (where normally the clamping takes place)

⁽²⁾ Only TSBF-C max. SMW-AUTOBLOK 166: General catalog