

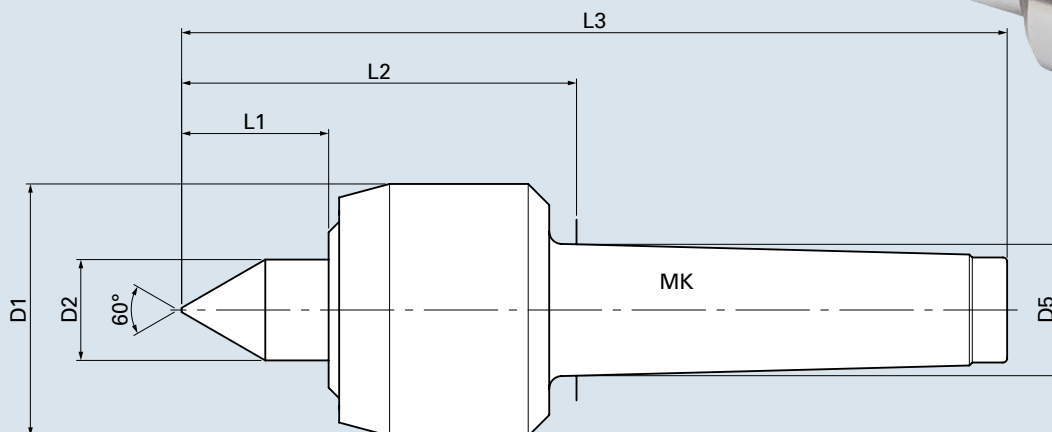

# NEIDLEIN Live Center URN/URC

Clamping tools for clamping on machine tools

## Type URN with morse taper



cat. no.	type	MK	D1	D2	D5	L1	L2	L3	rpm max. [1/min]	weight of work piece max. [kg]
85001	URN MK2	2	45	20	17.78	25	74	138	5000	150
85002	URN MK3	3	45	20	23.83	25	77	158	5000	200
85003	URN MK4	4	60	24	31.27	32	94	196.5	4300	500
85004	URN MK5	5	78	32	44.4	46	115	244.5	3200	1200

true running accuracy max. 0.005 guaranteed

## Type URC with morse taper

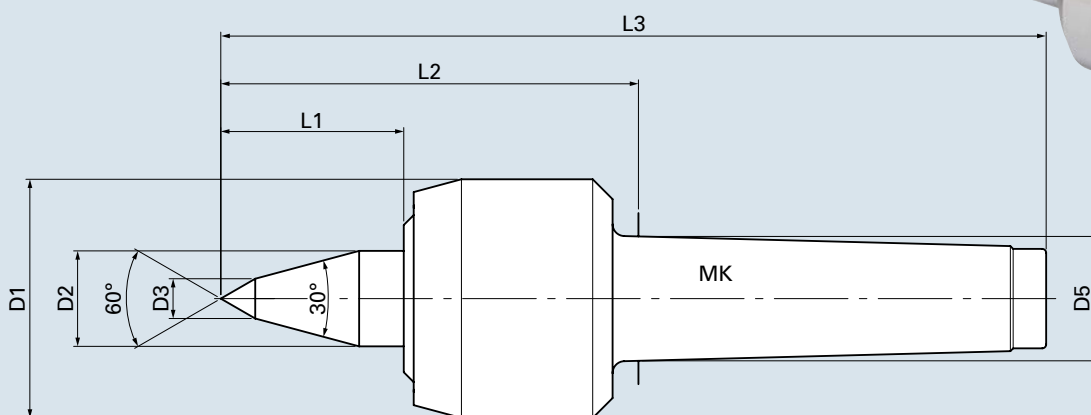

cat. no.	type	MK	D1	D2	D3	D5	L1	L2	L3	rpm max. [1/min]	weight of work piece max. [kg]
85101	URC MK2	2	45	20	8	17.78	36	85	149	5000	100
85202	URC MK3	3	45	20	8	23.83	36	85	169	5000	150
85303	URC MK4	4	60	24	10	31.27	46	105	207.5	4300	400
85404	URC MK5	5	78	32	10	44.4	60	128	257.5	3200	1200

true running accuracy max. 0.005 guaranteed