

# Face Drivers for Milling

- FDNC  
Standard with Flange  
Retainer
- FDNC  
Changeable Parts
- FDNC  
Special Face Drivers



# Face Drivers FDNC

## Clamping tools for milling between center pins

Face drivers for clamping work pieces for milling free from backlash for gear hobbing, keyway milling and other surfaces.

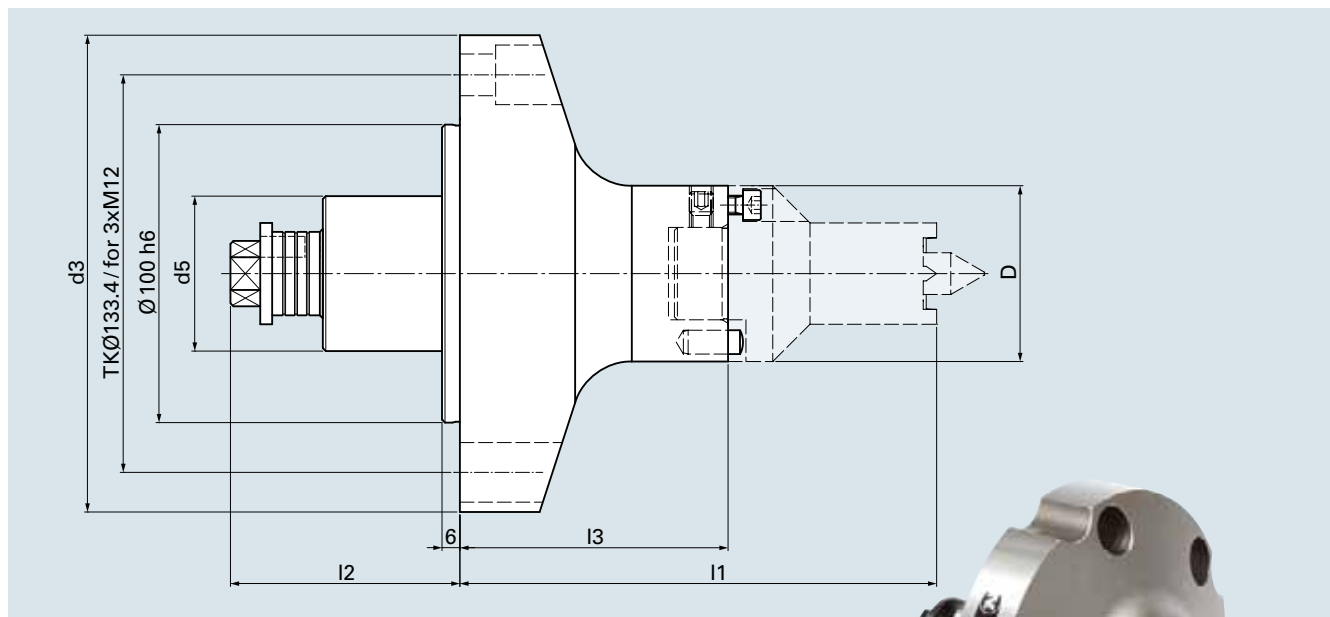
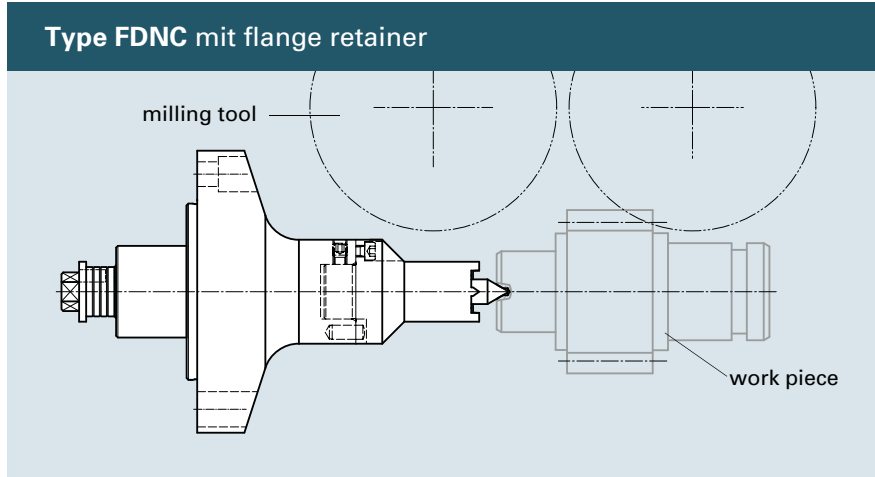

FDNC basic body without changeable parts

cat. no.	type	D	d3	d5	l1	l2	l3
73201	FDNC 11-4	59	160	52	160	77	90



fig. face driver complete with changeable parts

### NEIDLEIN face drivers type FDNC ensure:

- machining free from backlash due to fixed driving elements
- stability and retaining of high transverse thrust using adjustable, spring-loaded center pins
- constant datum point on end face of work piece
- adjustment of dissimilar bore holes
- adjustment true at drive cone for high true running accuracy
- tapered construction for optimum tool path



## Drive Heads FDNC

Changeable drive heads for basic body type FDNC



Type FDNC drive head

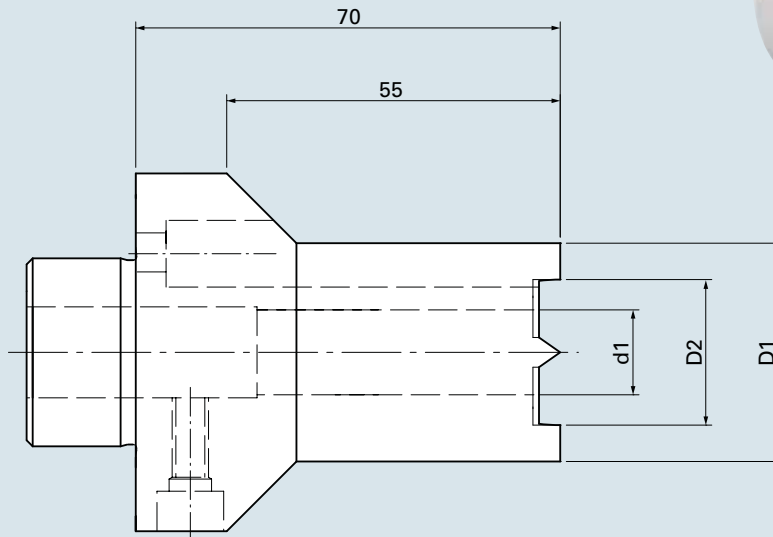

cat. no.	type	D1	D2	d1
<b>73701</b>	<b>11.11</b>	11	7	6
<b>73702</b>	<b>11.14</b>	14	9	6
<b>73703</b>	<b>11.18</b>	18	12	6
<b>73704</b>	<b>1.22</b>	22	14	8
<b>73705</b>	<b>1.26</b>	26	18	8
<b>73706</b>	<b>2.30</b>	30	20	14

cat. no.	type	D1	D2	d1
<b>73707</b>	<b>2.36</b>	36	24	14
<b>73708</b>	<b>3.39</b>	39	29	18
<b>73709</b>	<b>3.44</b>	44	34	18
<b>73710</b>	<b>4.49</b>	49	39	24
<b>73711</b>	<b>4.59</b>	59	49	24

## Center Pin FDNC

Changeable center pins for basic body and drive heads type FDNC



Type FDNC center pin

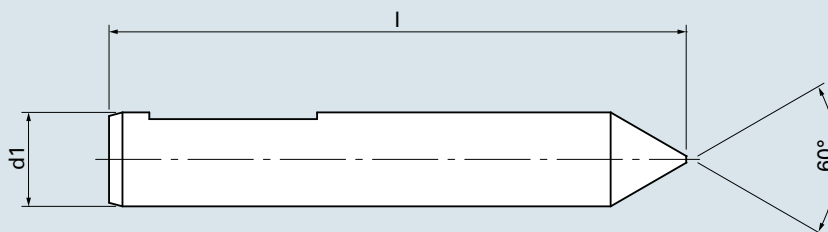

cat. no.	type	d1	l	center Ø
<b>73301</b>	<b>11</b>	6	78	1 - 6
<b>73302</b>	<b>1</b>	8	80	1 - 8
<b>73303</b>	<b>2</b>	14	86	1 - 14

cat. no.	type	d1	l	center Ø
<b>73304</b>	<b>3</b>	18	89	3 - 18
<b>73305</b>	<b>4.1</b>	24	89	3 - 18
<b>73306</b>	<b>4.2</b>	24	96	16 - 24



## Special Face Drivers FDNC

### Clamping tools for milling between centers

#### Made to measure

In order to meet the complex requirements of our customers and to cover the various spindle mounting options of machine tools, we develop and produce FDNC special face drivers for clamping work pieces.

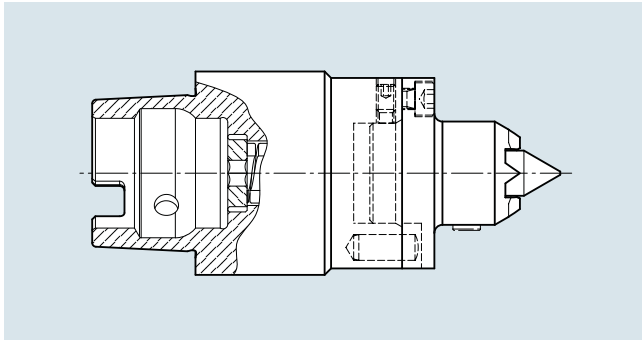

Type FDNC with taper shank retainer HSK

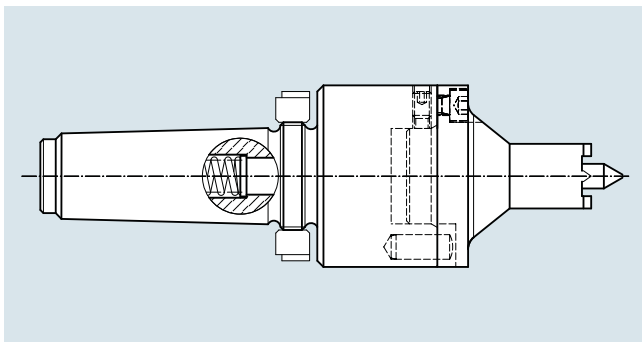

Type FDNC with taper shank retainer MK

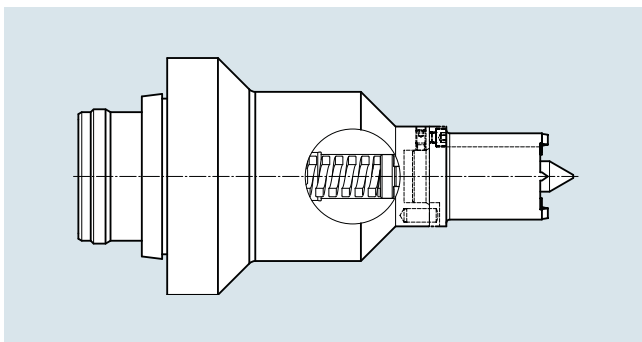

Type FDNC with special short taper

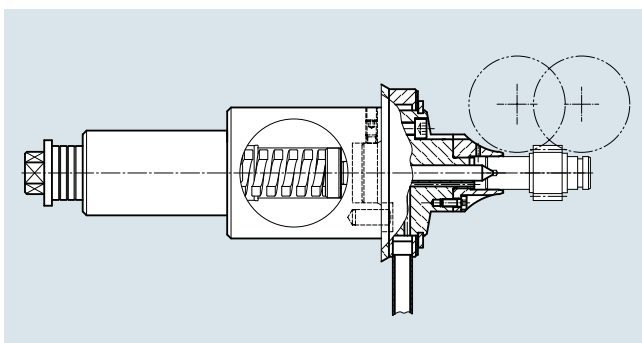

Type FDNC special with centering gauge and flush fluid

